

Ny utgave 2011

Vg2 elektro

Teori med
praktiske
øvinger

Kunnskaps-
løftet

Frank Fosbæk

Automatiserte anlegg

Vg2 automatisering

ELFORLAGET

Illustrasjoner til Automatiserte anlegg Vg2 automatisering

Kapittel 13

Illustrasjonene kan brukes fritt i undervisningen

© Elforlaget 2011

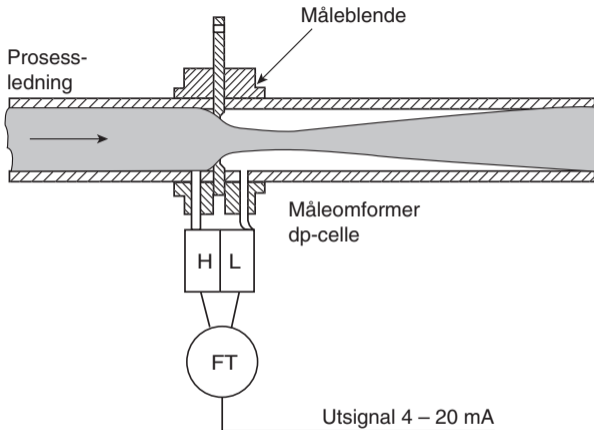
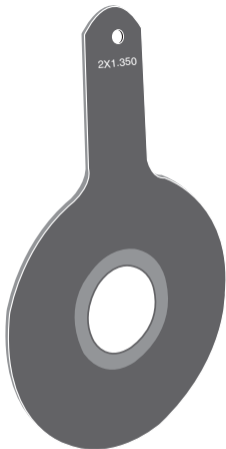

Figur 13.1 Måleblende og hvordan måleblenden er montert inn i prosessledningen

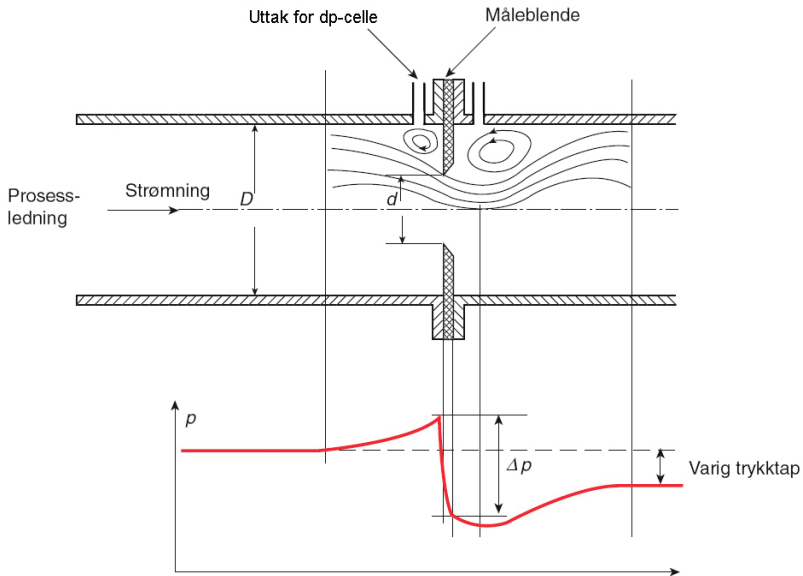

Figur 13.2 Trykkfallet over måleblenden

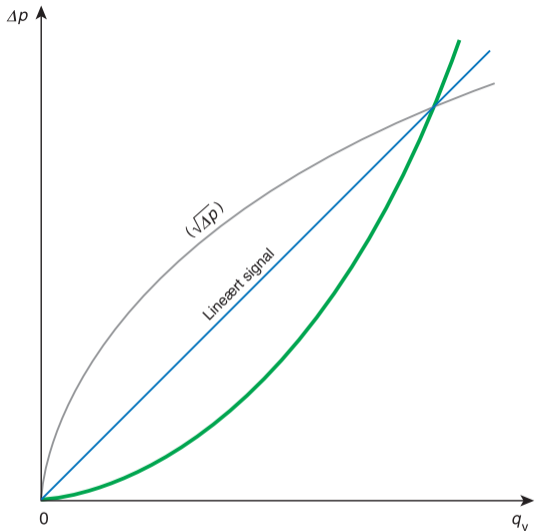

Figur 13.3 Trykkforskjellen over måleblenden ved strømning

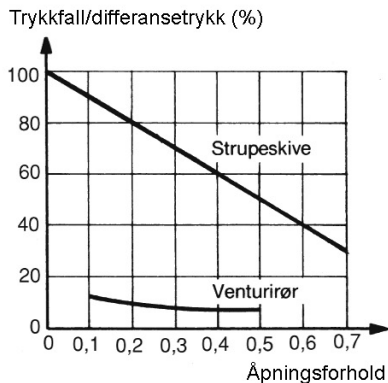
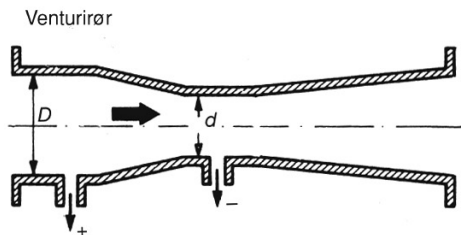
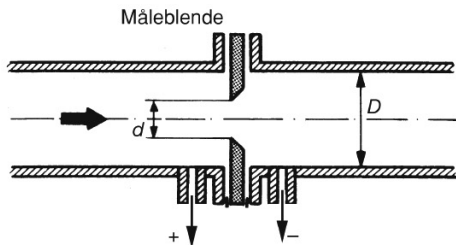

Figur 13.4 Måleblende og venturirør montert i en prosessledning. Diagrammet viser forholdet mellom trykkfallet og åpningsforholdet

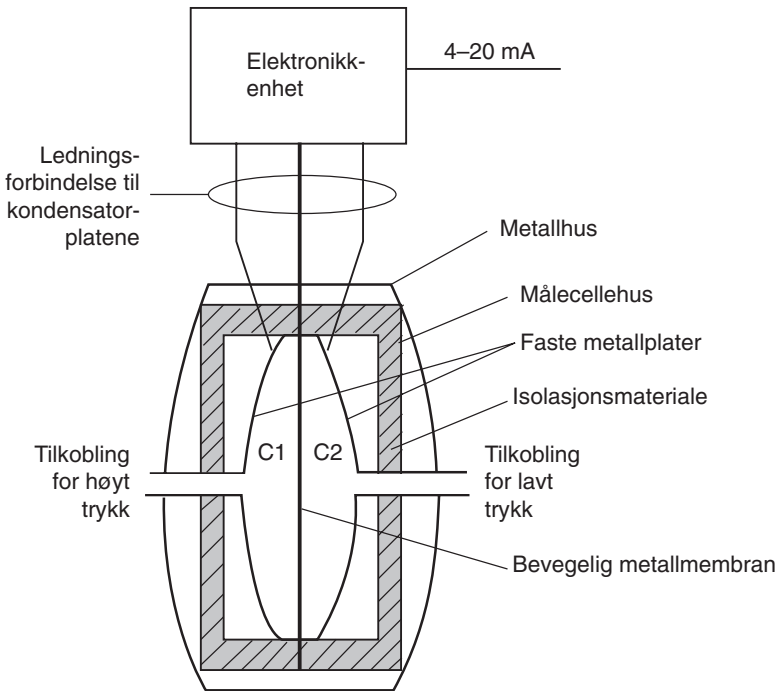

Figur 13.5 Skisse av gjennomskåret målecellehus med elektronisk enhet

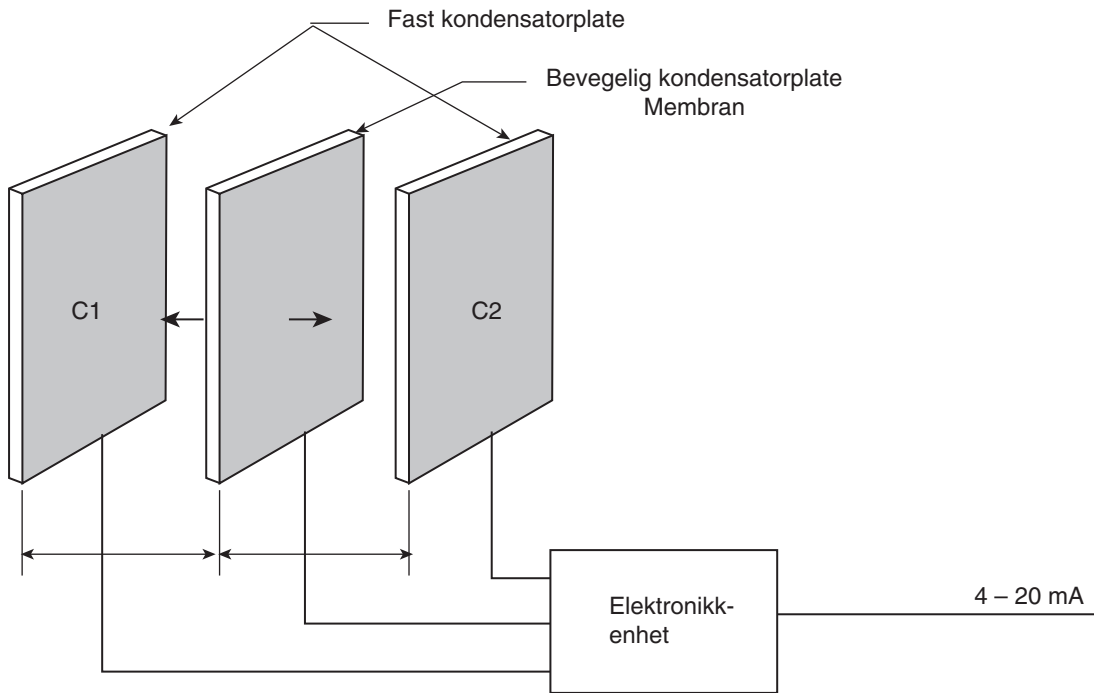

Figur 13.6 Differensialkondensator

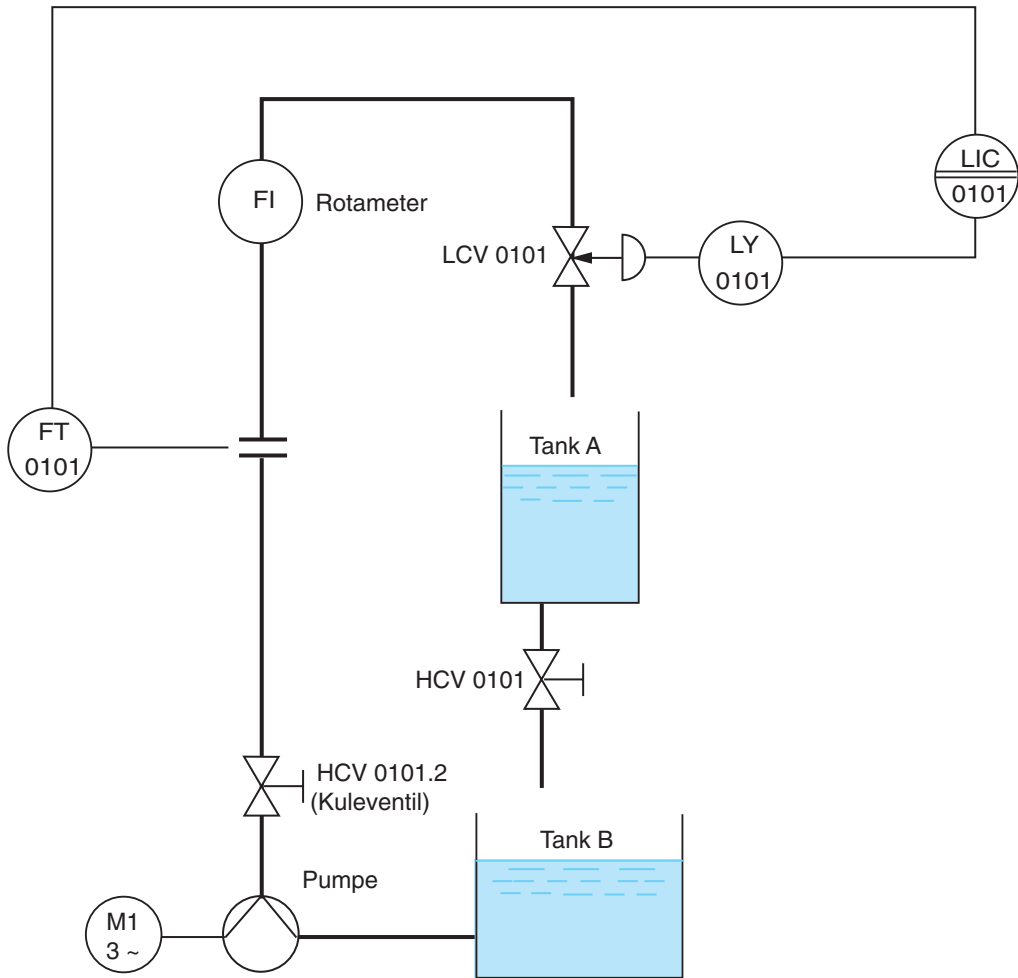

Figur 13.7 Skjema for prøveoppkobling

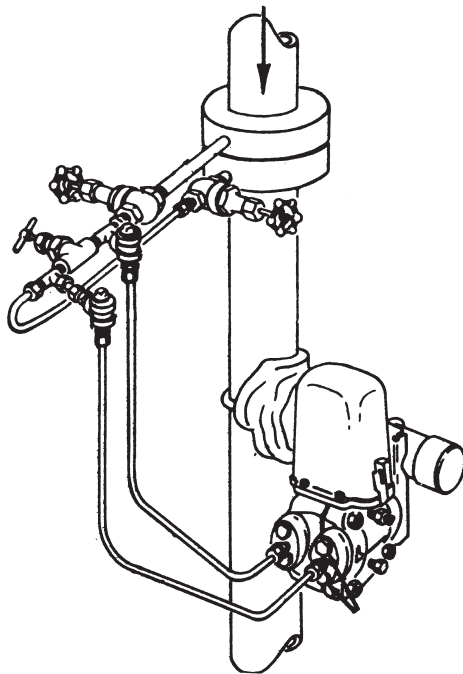
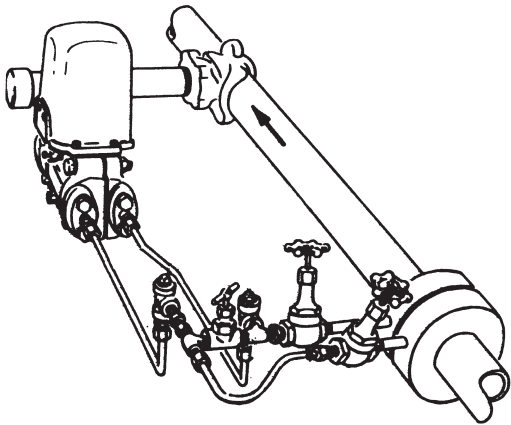

Figur 13.8 Eksempel på montering av dp-celle

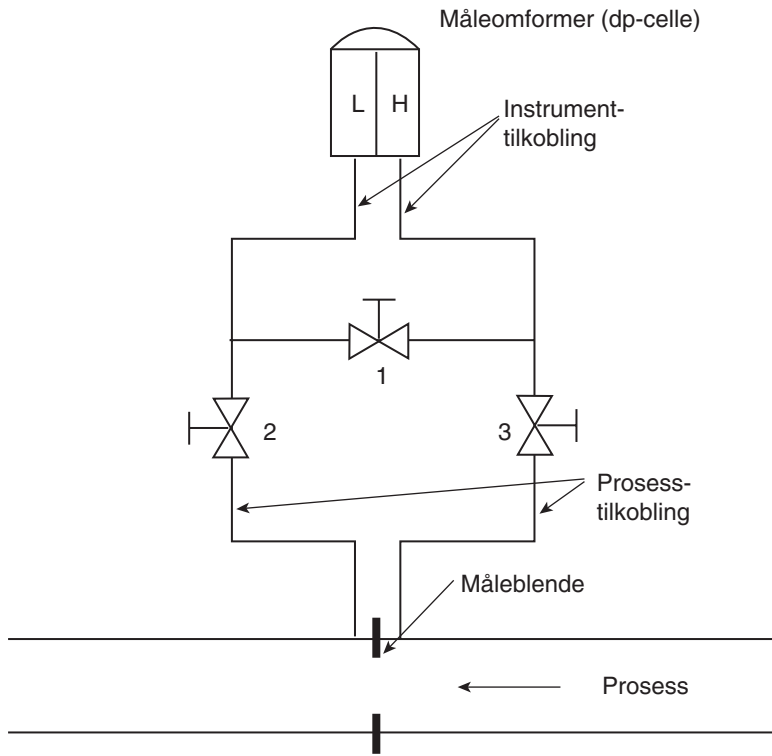

Figur 13.9 Prinsippskisse av kobling av manifold med tre ventiler

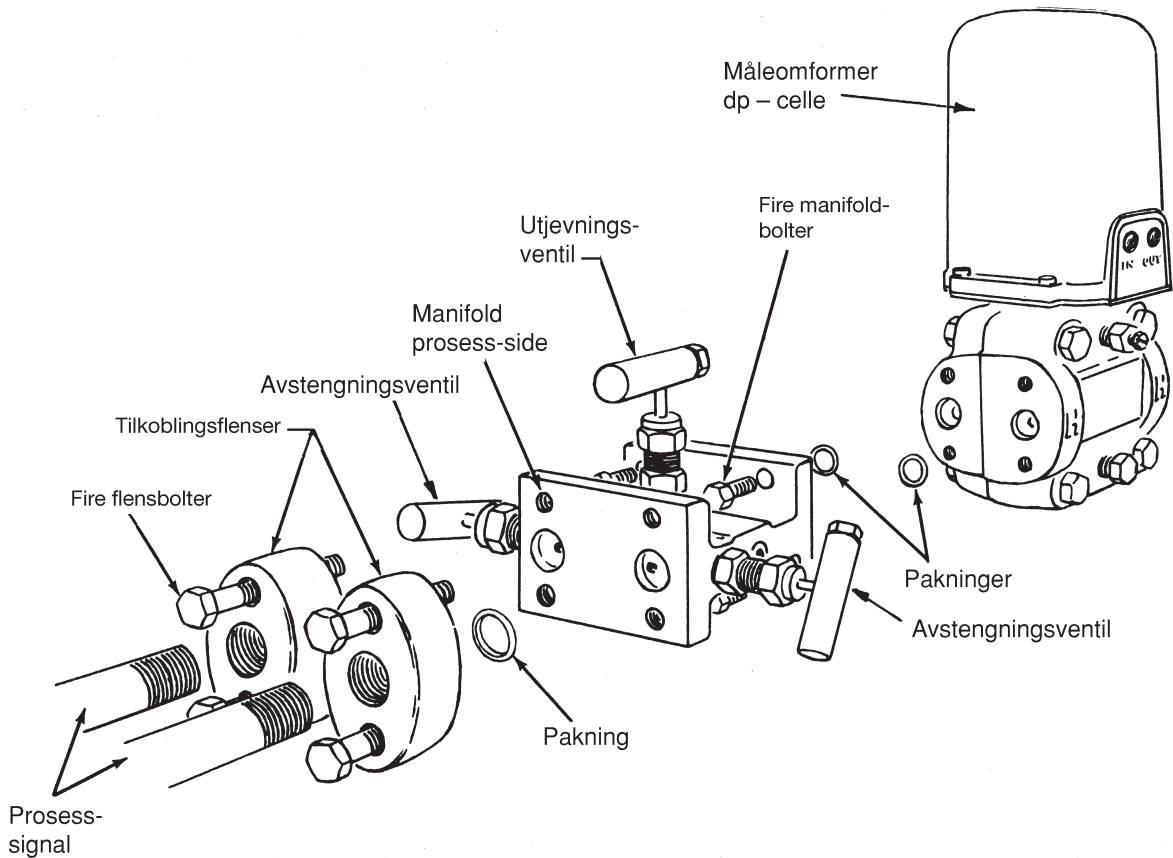

Figur 13.10 Praktisk utførelse av blandedbatteri

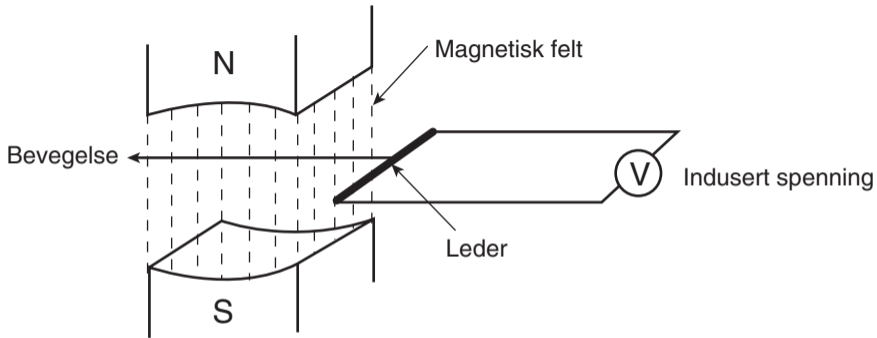

Figur 13.11 Prinsippet for elektrisk induksjon

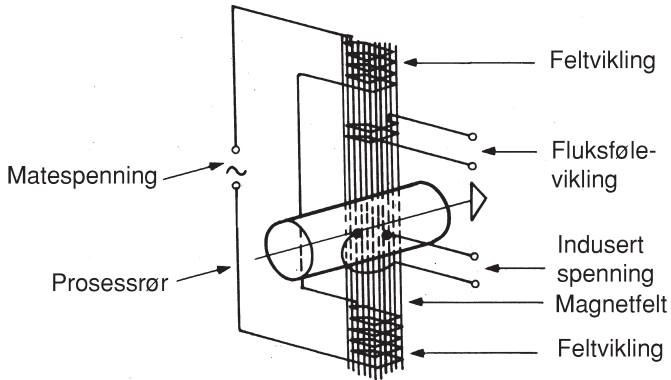

Figur 13.12 Prinsippet for magnetisk mengdemåler

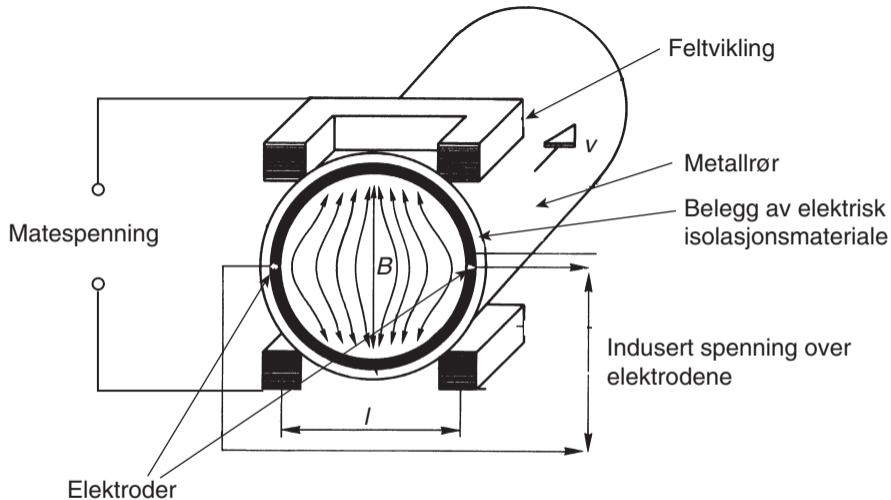

Figur 13.13 Skisse av målerøret