

Ny utgave 2011

Vg2 elektro

Teori med  
praktiske  
øvinger

Kunnskaps-  
løftet

Frank Fosbæk

# Automatiserte anlegg

## Vg2 automatisering

*ELFORLAGET*

# Illustrasjoner til Automatiserte anlegg Vg2 automatisering

## Kapittel 15

Illustrasjonene kan brukes fritt i undervisningen

© Elforlaget 2011

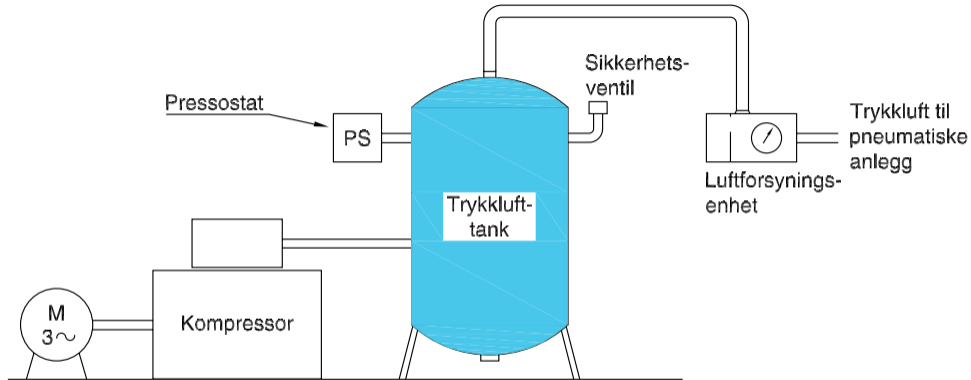

**Figur 15.1** Prinsippskisse av et trykkluftanlegg

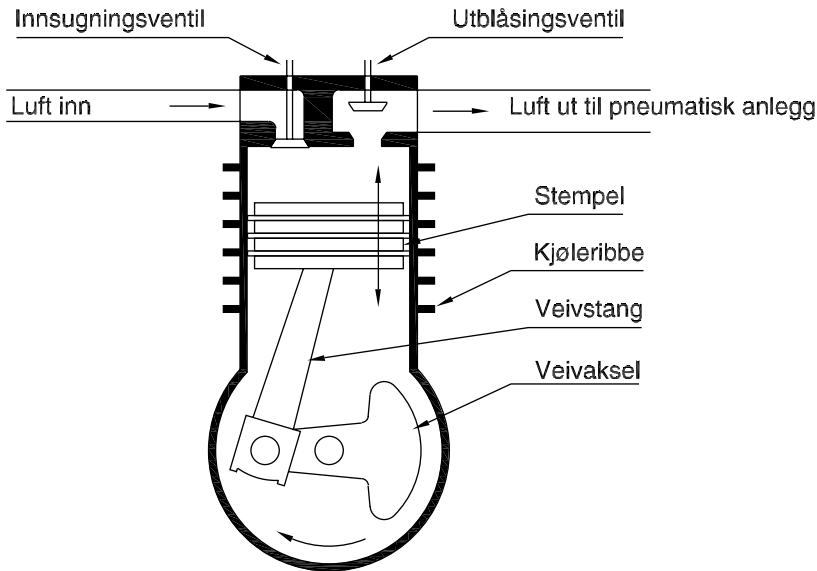

**Figur 15.2** Prinsippskisse av en stempelkompressor

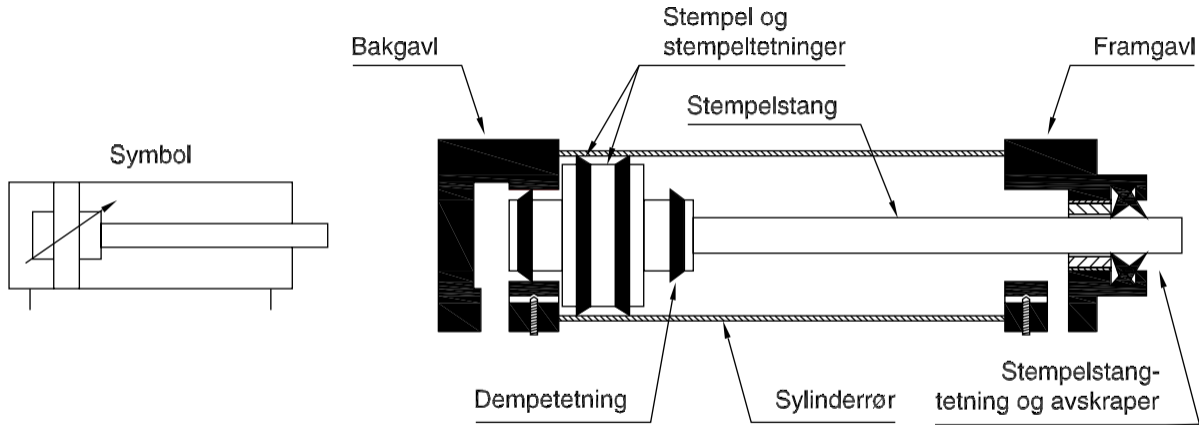

**Figur 15.3** Dobbeltvirkende sylindere med endedempning

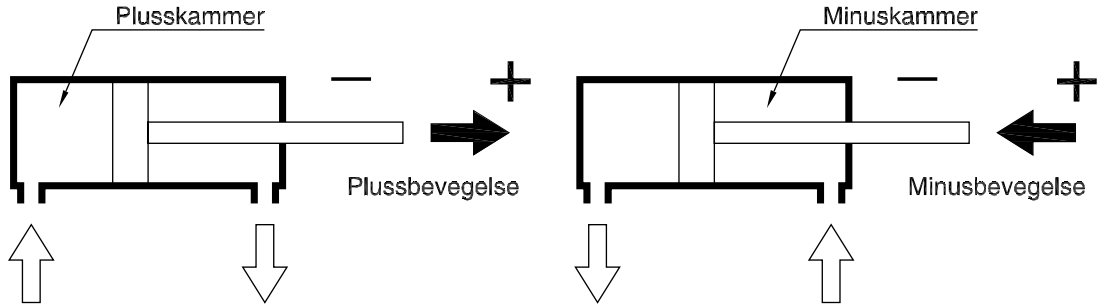

**Figur 15.4 Pluss- og minuskammer og stempelbevegelsen til en dobbeltvirkende sylinder**

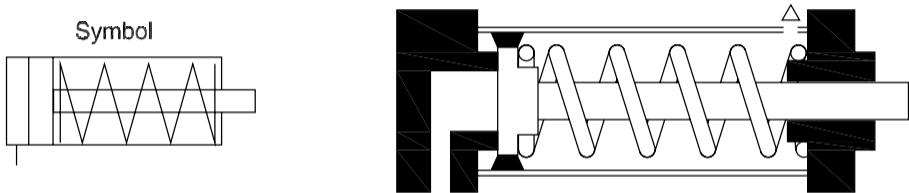

**Figur 15.5 Enkeltvirkende sylinder med returfjær**

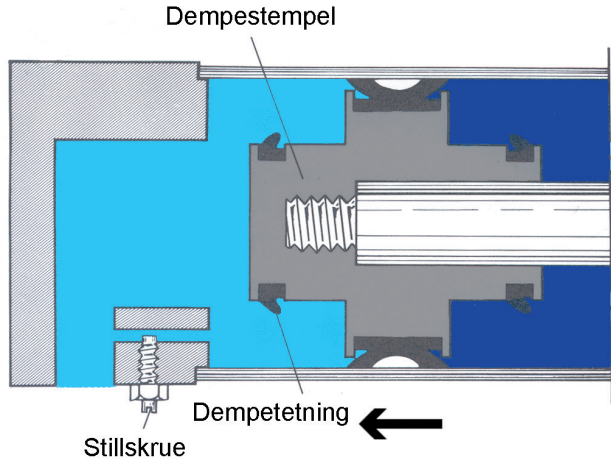
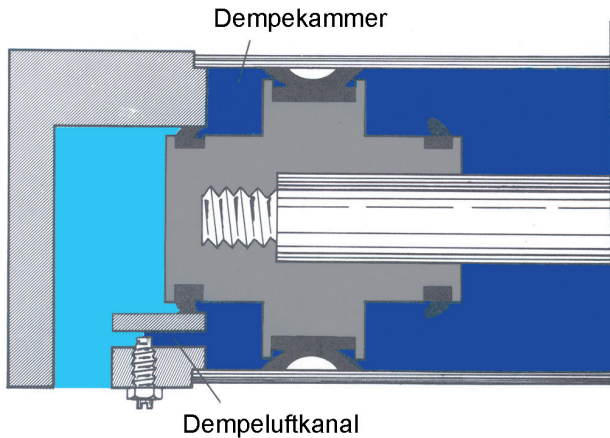

**Figur 15.6** Luftdemping av stempelbevegelsen



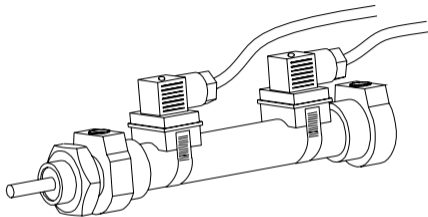
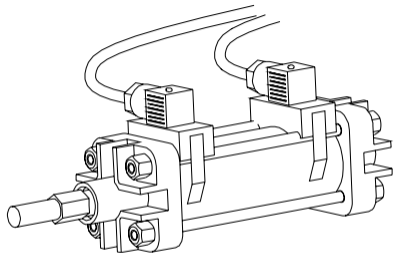

**Figur 15.7** Sylinder med magnetstempel og magnetbrytere monteret utenpå cylinderrøret

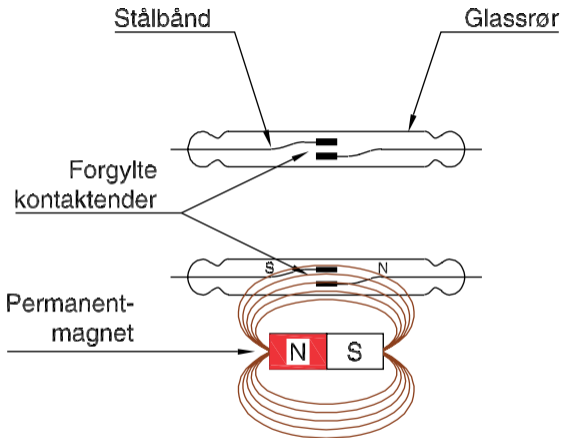

**Figur 15.8** Prinsippet for en magnetkontakt

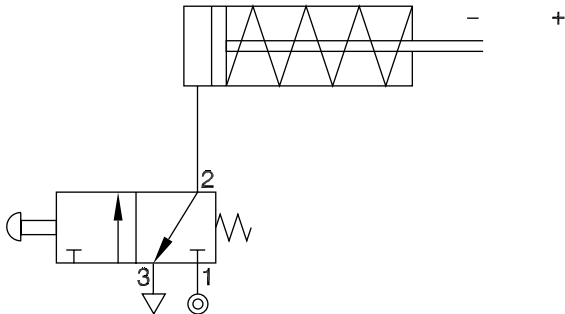

**Figur 15.9 Pneumatisk koblingskjema for styring av en enkeltvirkende sylinder med manuelt aktivert 3/2 ventil**

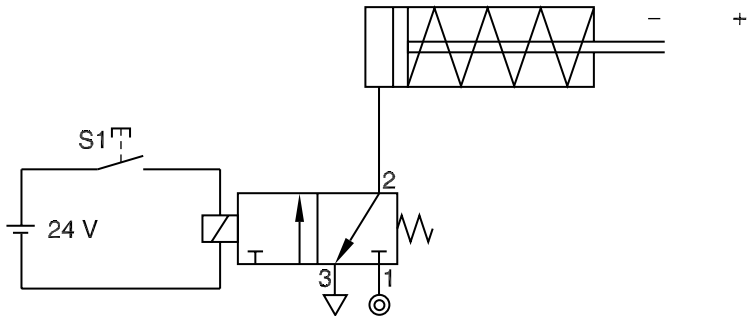

**Figur 15.10 Pneumatisk koblingskjema for elektrisk styring av en enkeltvirkende sylinder.**

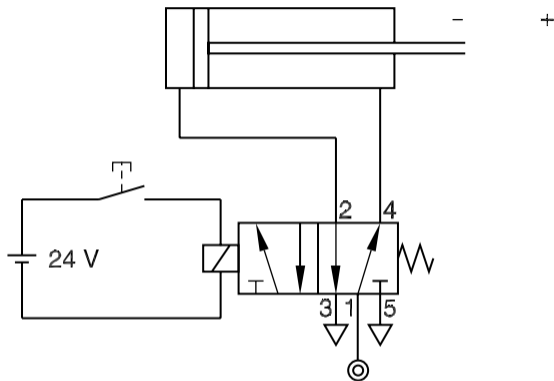

**Figur 15.11 Elektropneumatisk koblingskjema for elektrisk styring av en dobbeltvirkende sylinder**

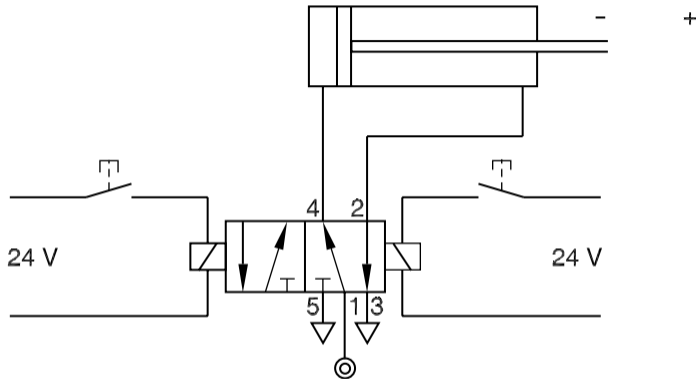

**Figur 15.12 Pneumatisk koblingskjema for elektrisk styring av en dobbeltvirkende sylinder med bistabil retningsventil**



**Figur 15.13**  
**Skjemasymbolet for**  
**strupeventil**



**Figur 15.14**  
**Skjemasymbolet for**  
**tilbakeslagsventil**



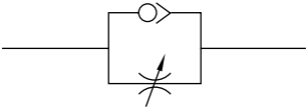

**Figur 15.15 Symbolet for  
strupetilbakeslagsventil**

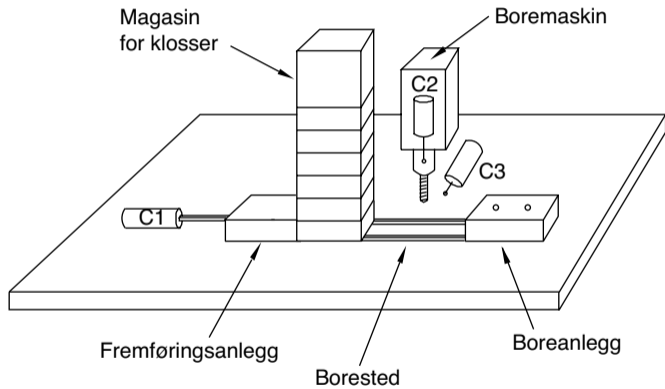
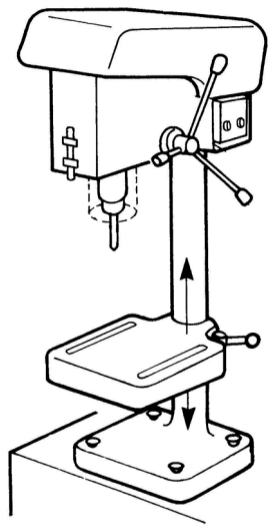

**Figur 15.16 Benkeboremaskinen og konstruksjonsskissen for boreoperasjonen**

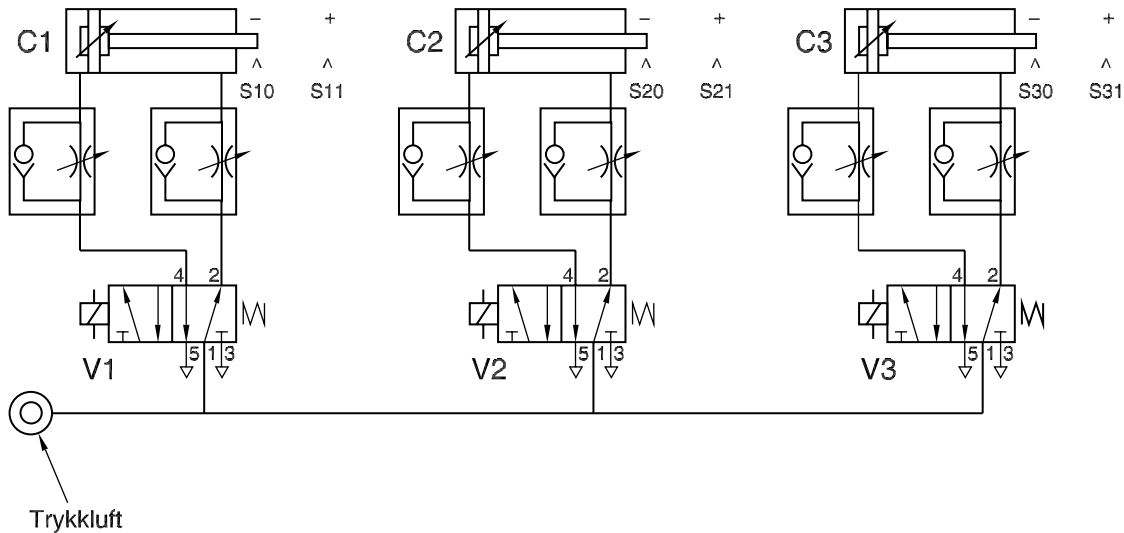

**Figur 15.17** Pneumatisk koblingskjema for anlegget

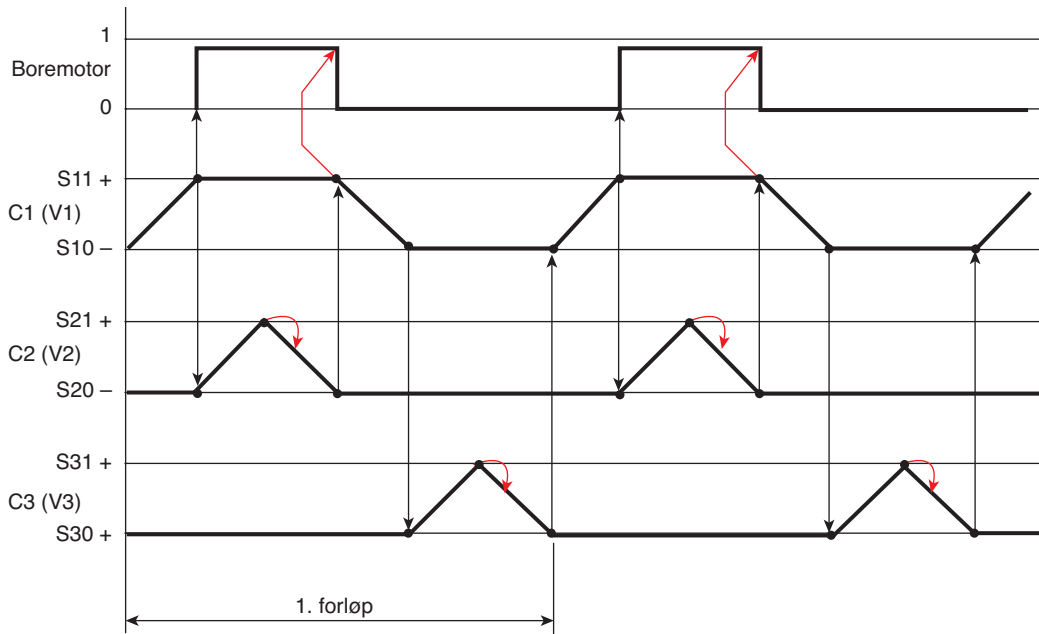

**Figur 15.18 Forløpsdiagram for sylinderbevegelesene**

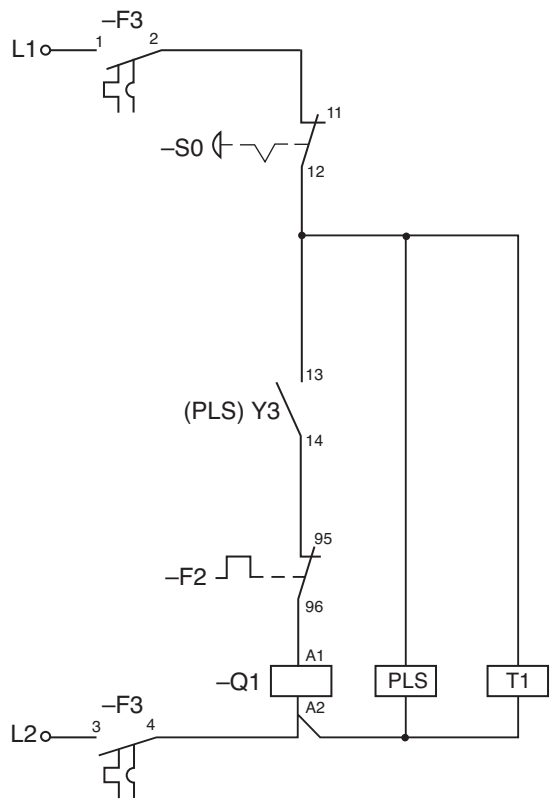
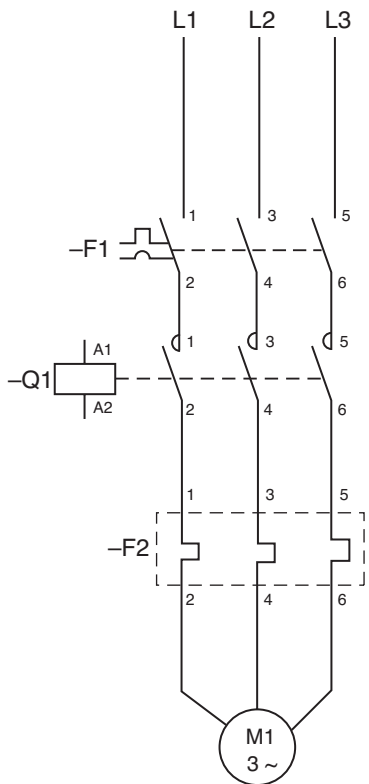

Figur 15.19 Hovedstrøms- og styrestrømsskjema

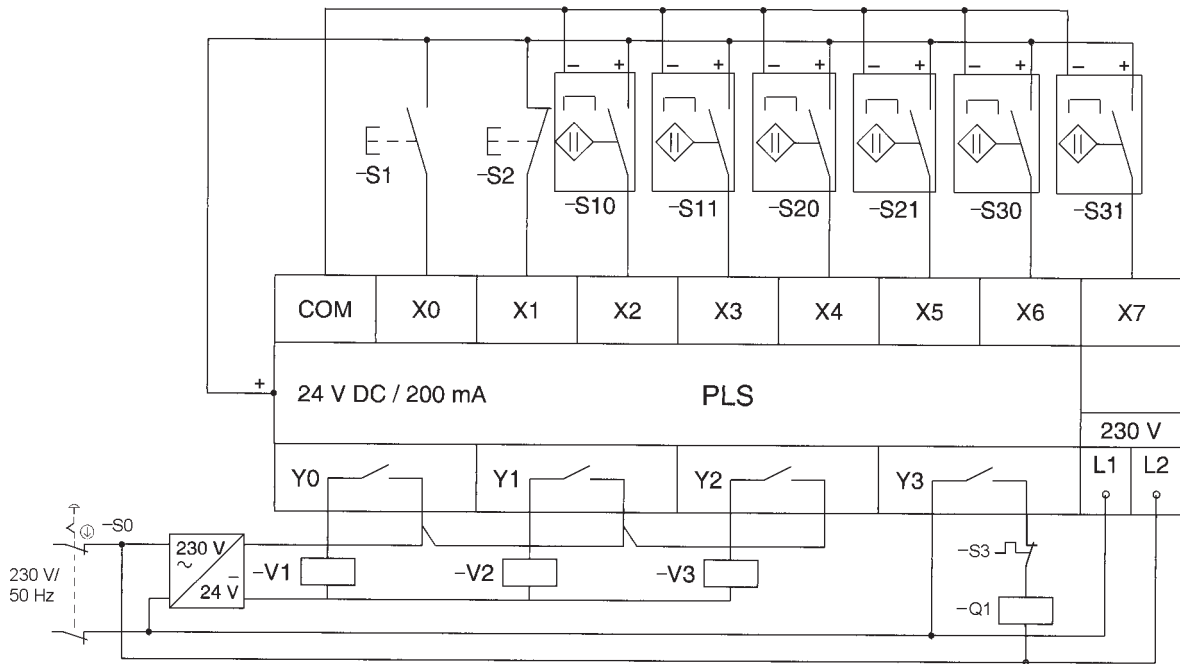

**Figur 15.20** PLS-tilkoblinger

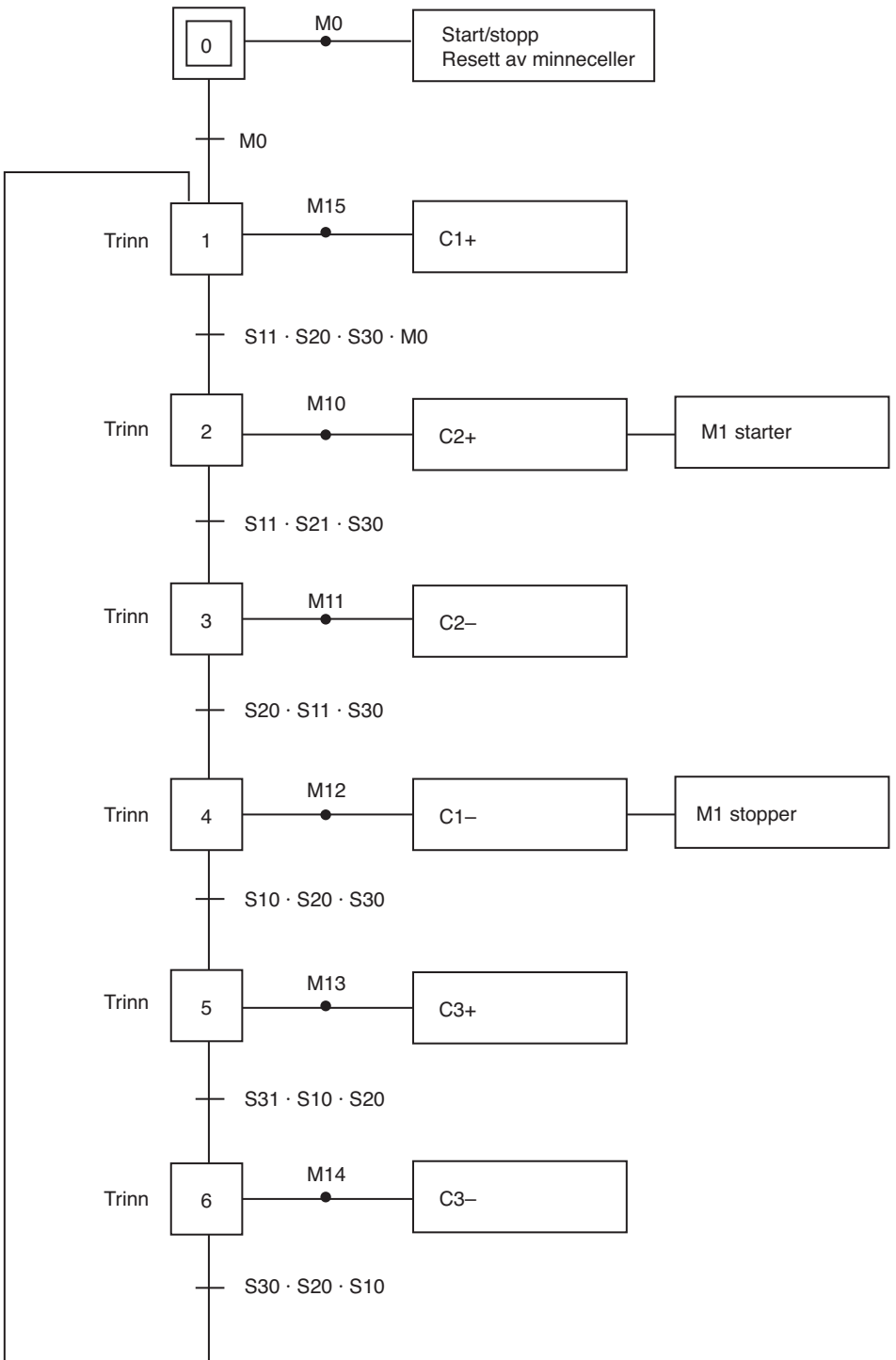

**Figur 15.21** Sekvensielt funksjonsdiagram

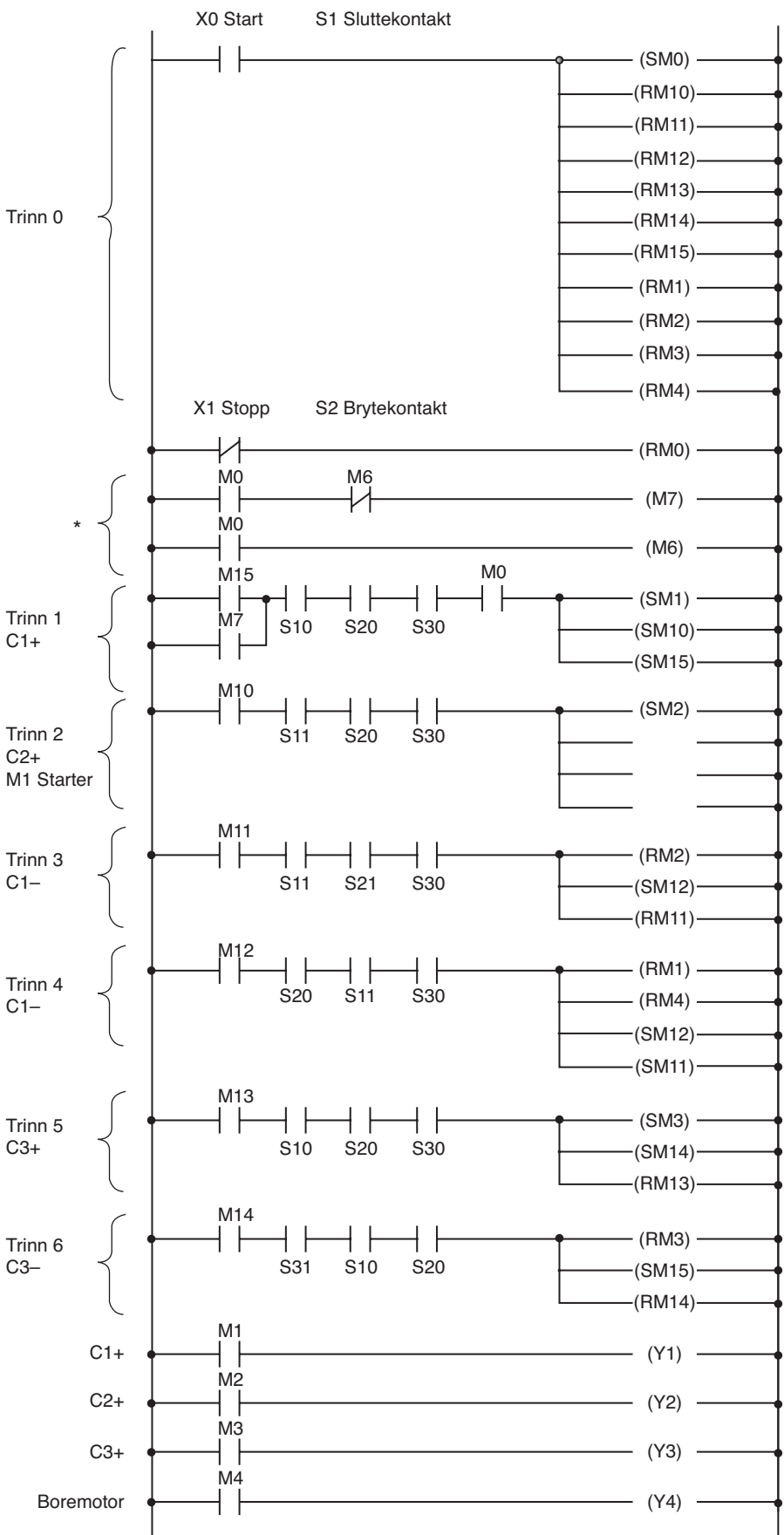

**Figur 15.22** Ladderdiagram