

Ny utgave 2010

Vg2 elektro

Teori med
praktiske
øvinger

Kunnskaps-
løftet

Frank Fosbæk

Automatiserte anlegg

Vg2 elenergi

ELFORLAGET

Illustrasjoner til Automatiserte anlegg Vg2 elenergi

Kapittel 7

Illustrasjonene kan brukes fritt i undervisningen

© Elforlaget 2011

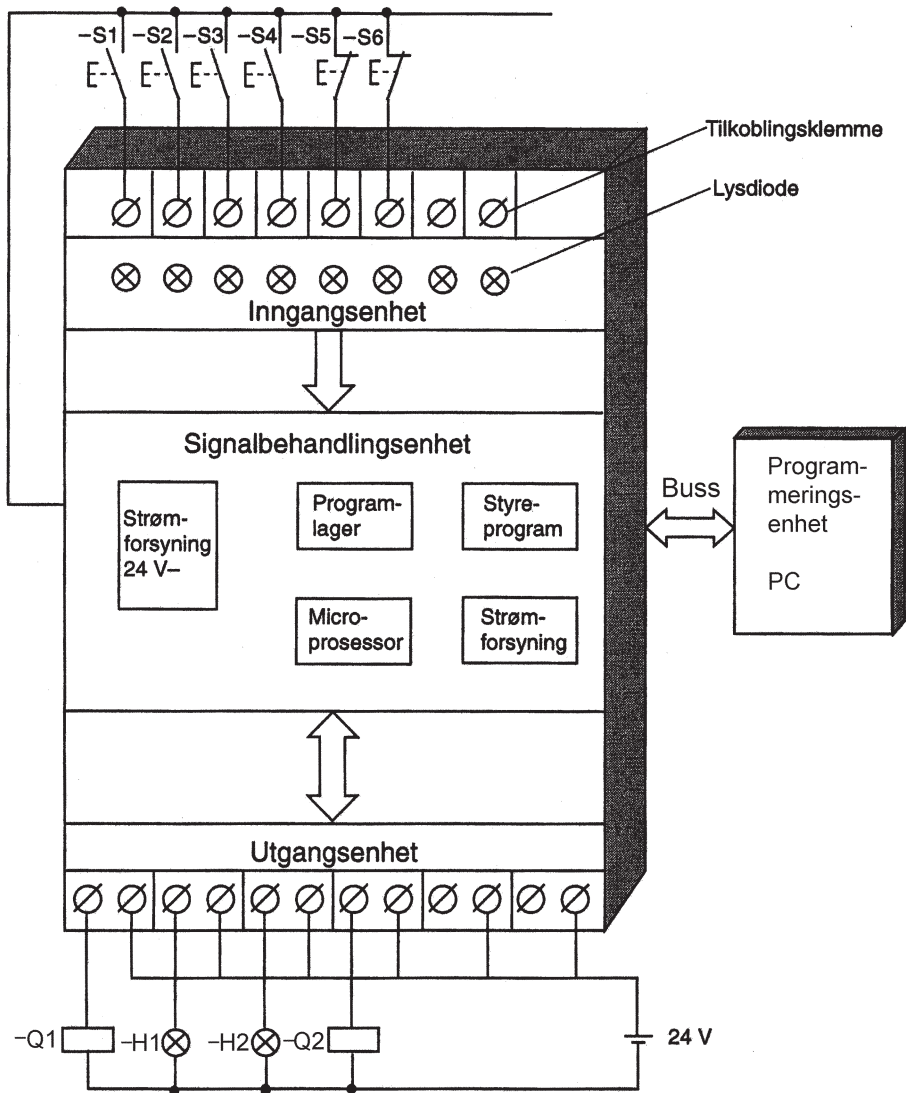

Figur 7.1 Prinsippskjema for en PLS

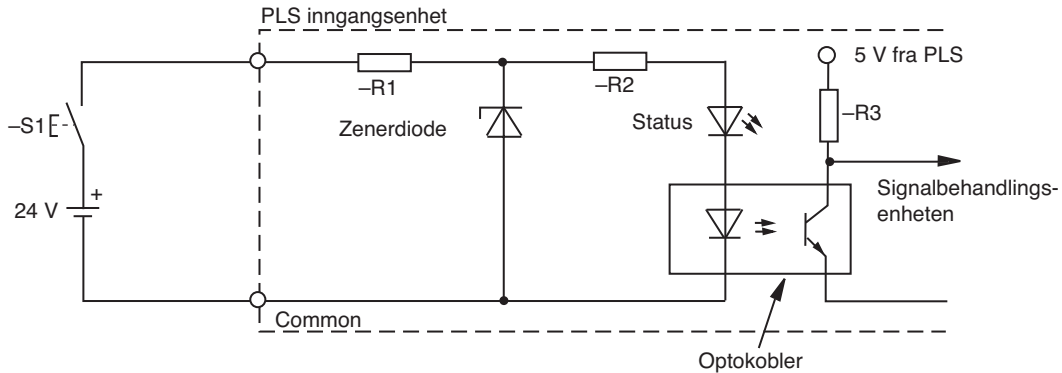

Figur 7.2 Prinsippskjema for en inngang med galvanisk skille

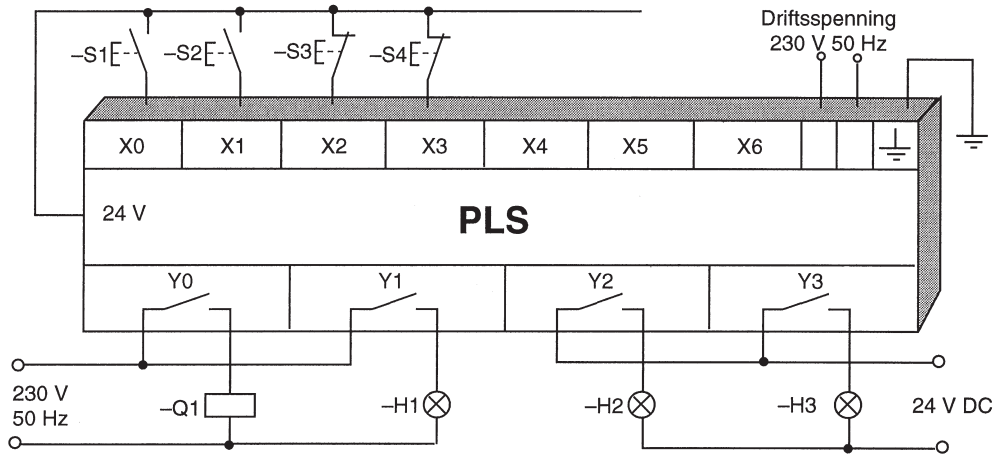

Figur 7.3 Eksempel på kobling av PLS

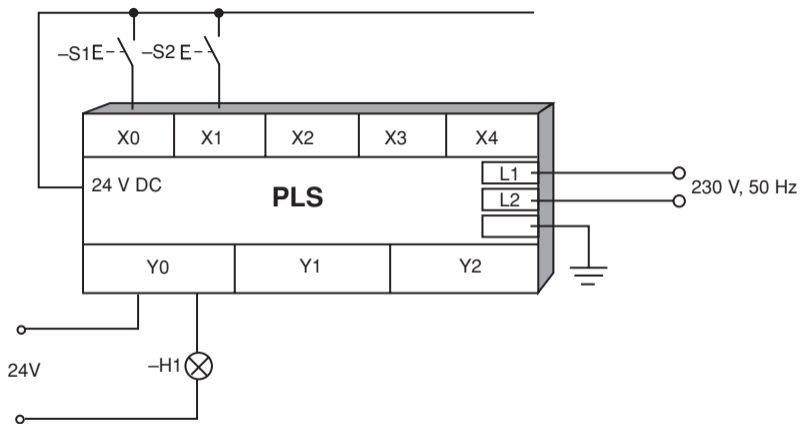

Figur 7.4 PLS med tilkoblinger

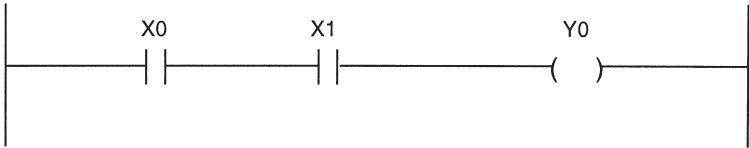

Figur 7.5 Ladderdiagram

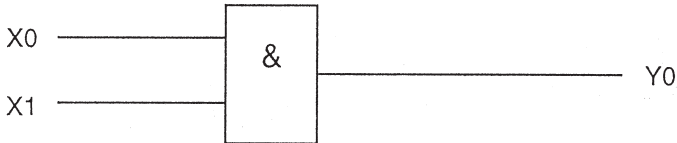

Figur 7.6 Funktionsblokkdiagram



Brytekontakt

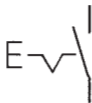

Sluttekontakt

Monostabile brytere

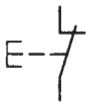

Brytekontakt

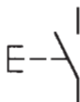

Sluttekontakt

Figur 7.7 Symboler for bistabile og monostabile brytere

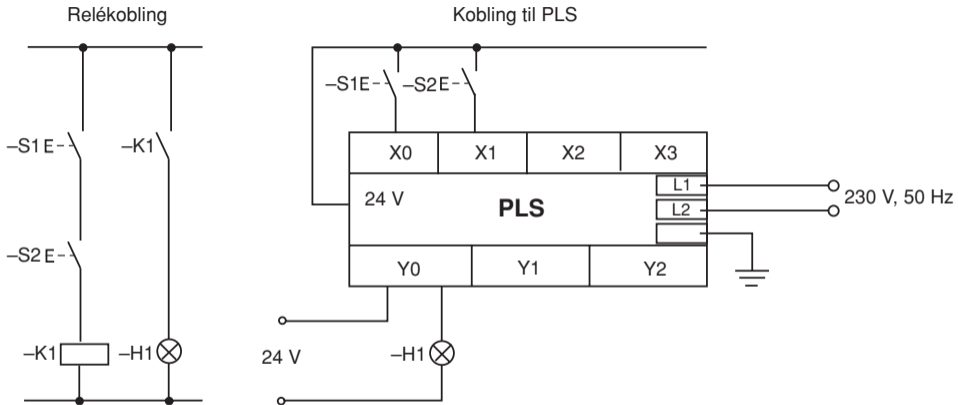

Figur 7.8 OG-funksjon

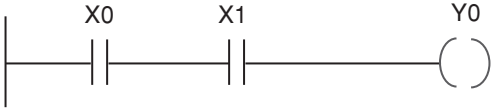

Figur 7.9 Ladderdiagram

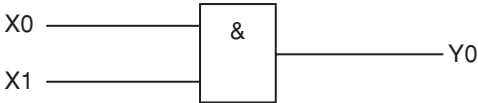

Figur 7.10 Funksjonsblokkdiagram

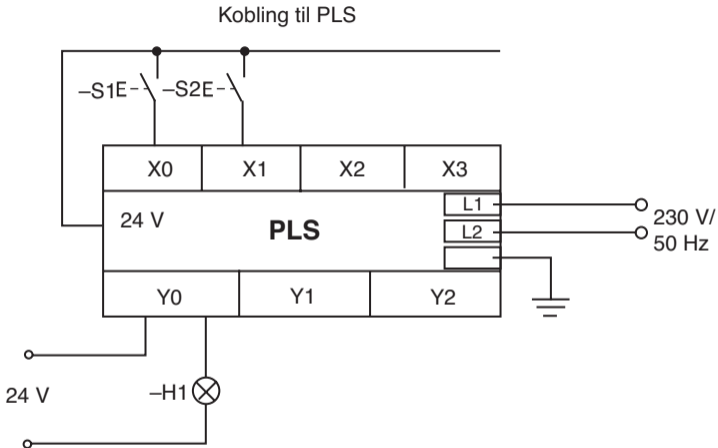
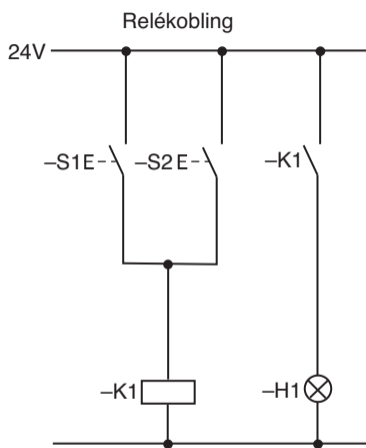

Figur 7.11 ELLER-funksjon

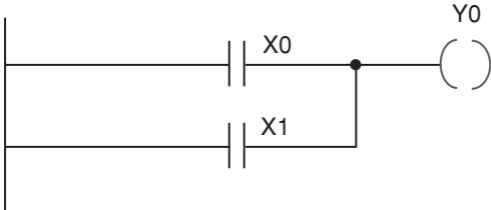

Figur 7.12 Ladderdiagram

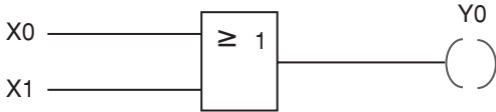

Figur 7.13 Funksjonsblokkdiagram

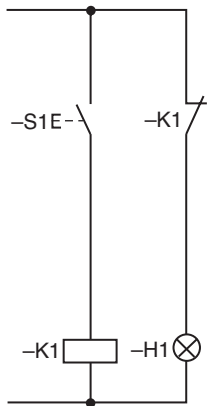

Reléstyring

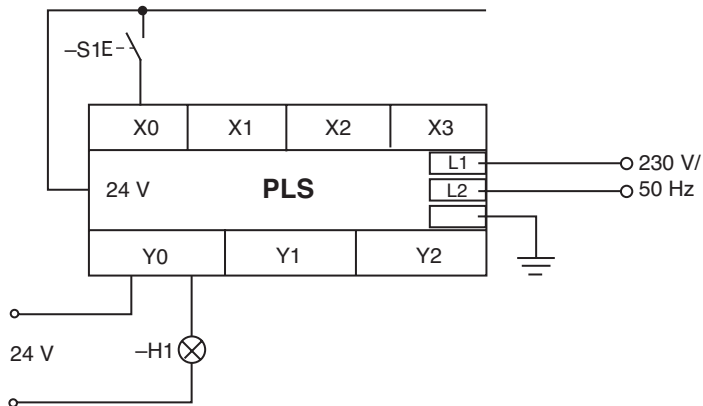

PLS-styring

Figur 7.14 Inverter-funksjon

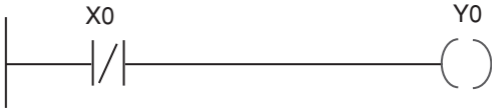

Figur 7.15 Ladderdiagram

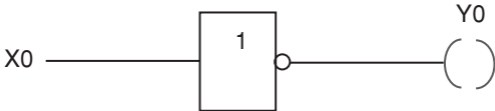

Figur 7.16 Funksjonsblokkdiagram

Relékobling:

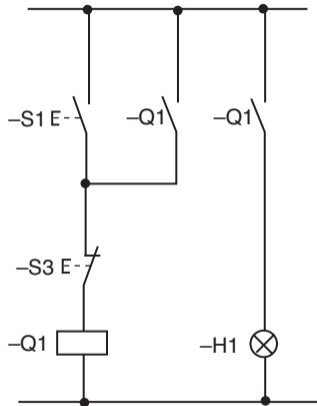

Kobling til PLS:

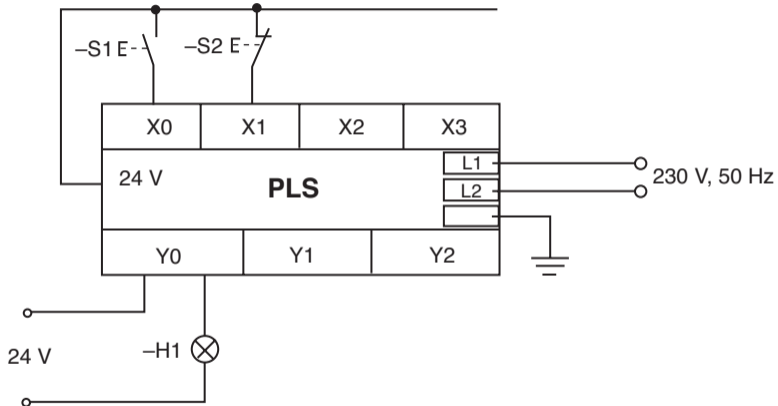

Figur 7.17 Holdefunksjon

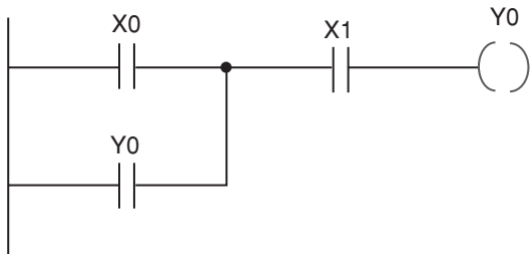

Figur 7.18 Ladderdiagram

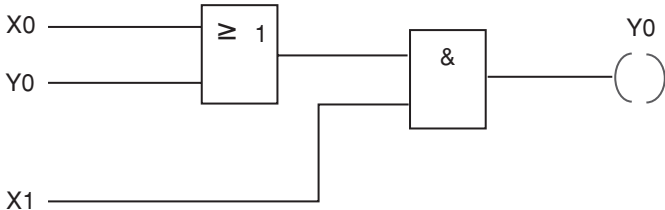

Figur 7.19 Funksjonsblokkdiagram

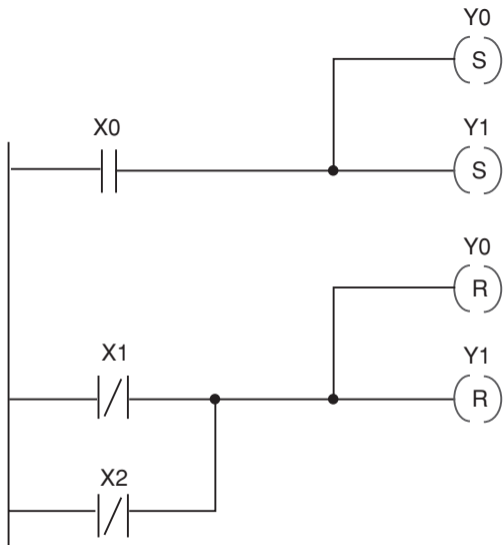

Figur 7.21 Ladderdiagram

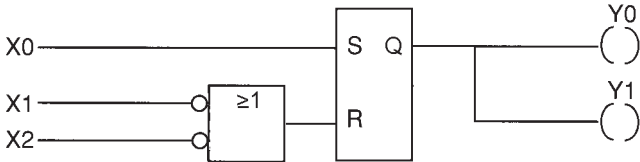

Figur 7.22 Funksjonsblokkdiagram

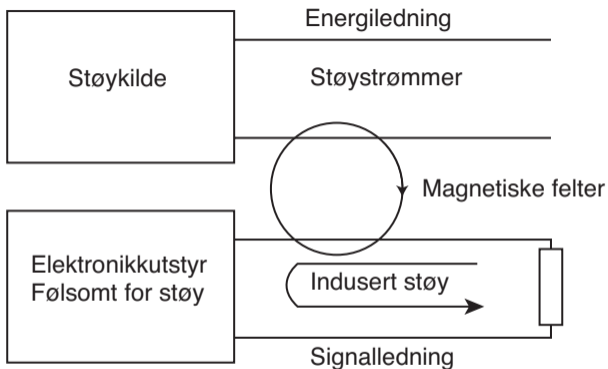

Figur 7.23 Indusert elektrisk støy

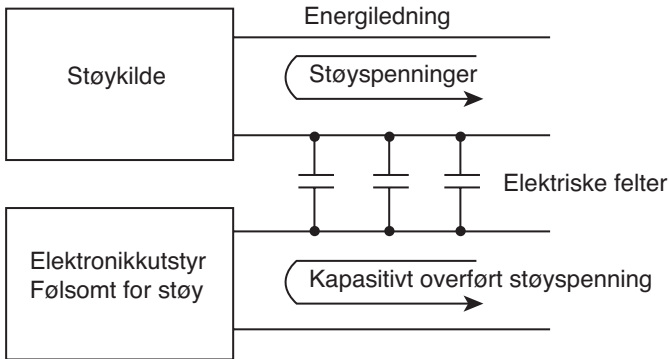

Figur 7.24 Kapasitivt overført støy

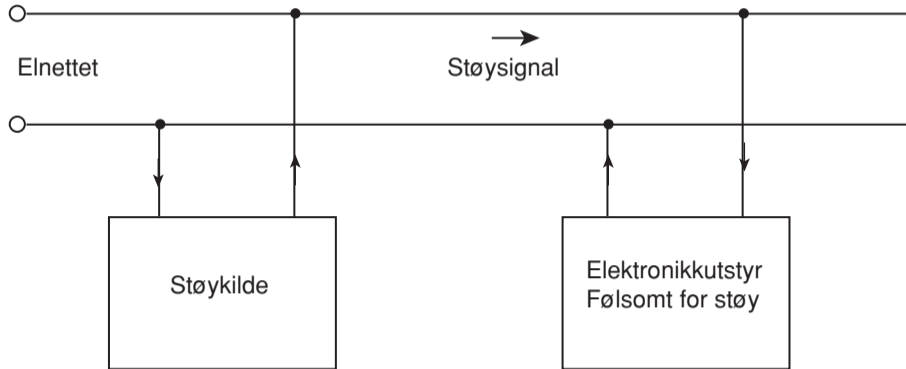

Figur 7.25 Overføring av støy gjennom ledningsnett

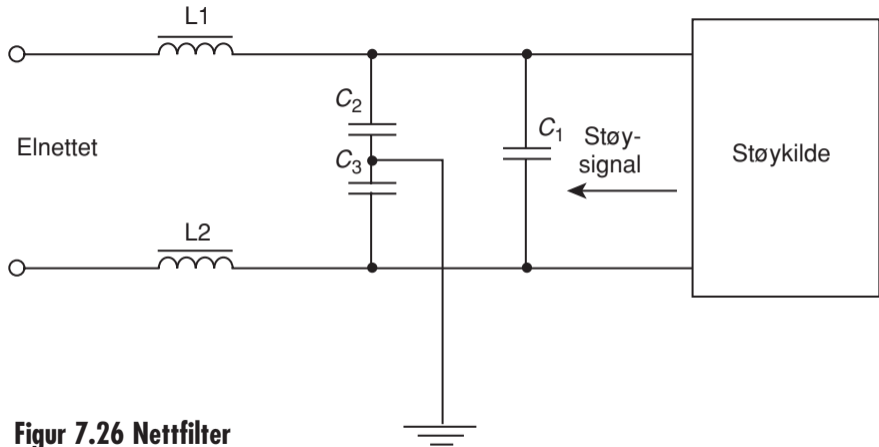

Figur 7.26 Nettfilter

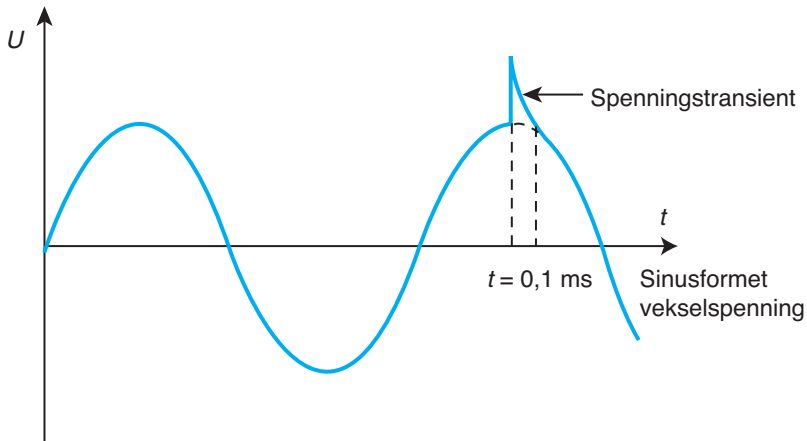

Figur 7.27 Eksempel på spenningstransient

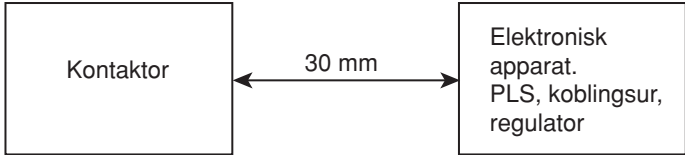

Figur 7.28 Eksempel på plassering av en kontaktor

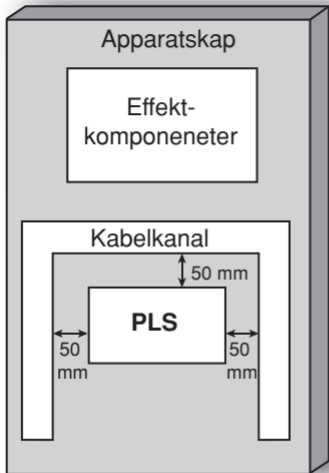

Figur 7.29 Plassering av apparater i apparatskap

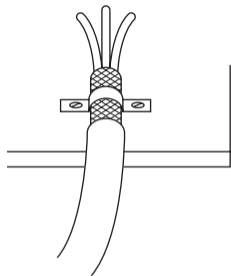

God

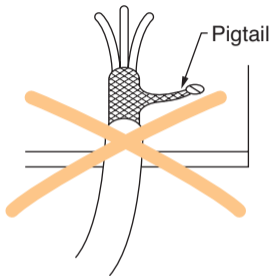

Dårlig

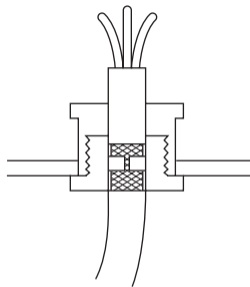

God

Figur 7.30 Eksempel på koblingen av en skjermkabels skjerm til jordskinnen

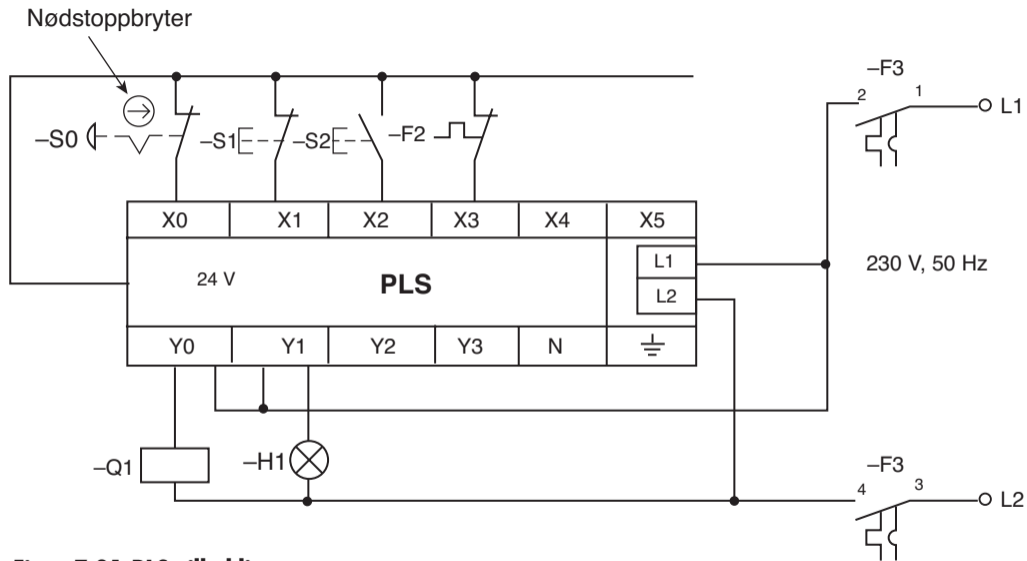

Figur 7.31 PLS-tilkoblinger

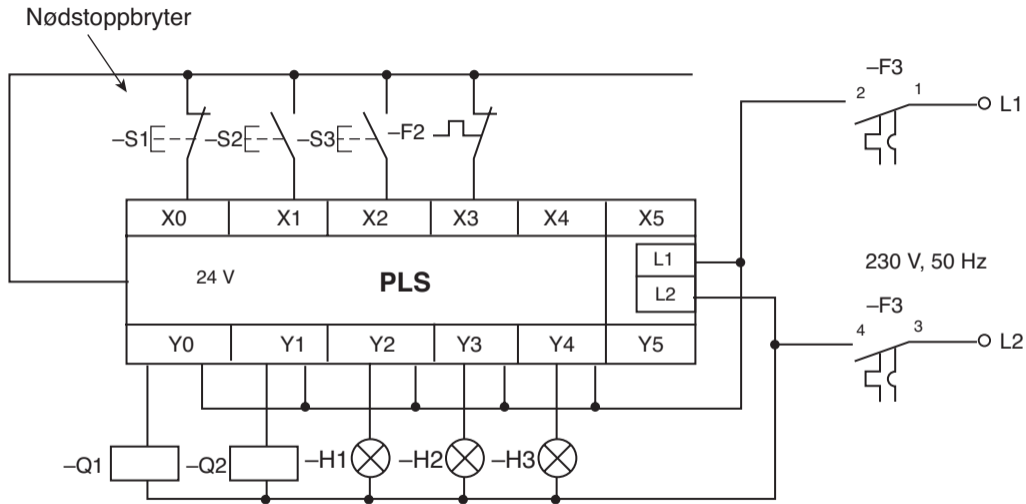

Figur 7.32 PLS-tilkoblinger

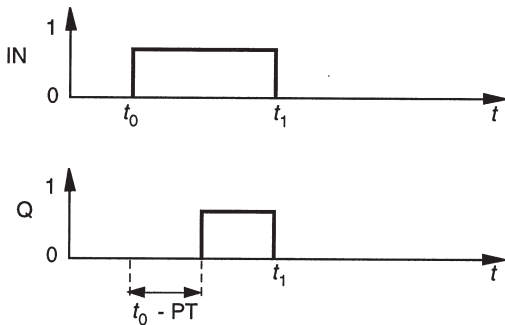
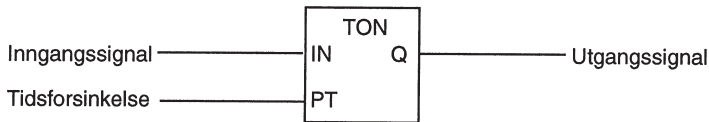

Figur 7.33 Forsinket innkobling

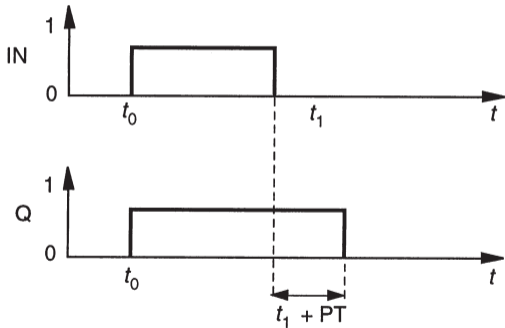
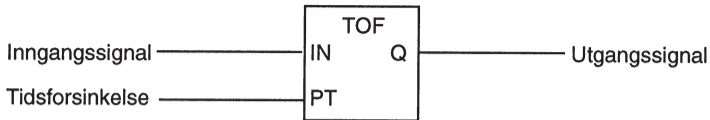

Figur 7.34 Forsinket utkobling

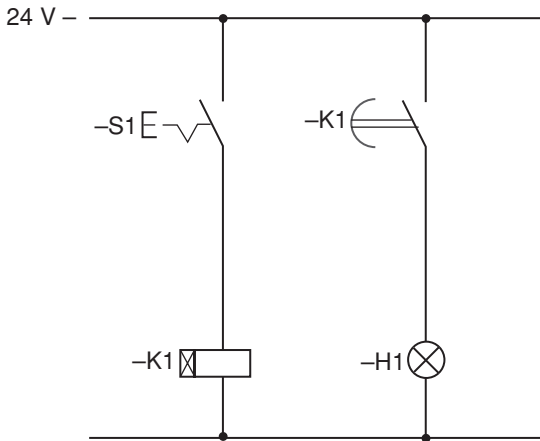

Figur 7.35 Relékobling

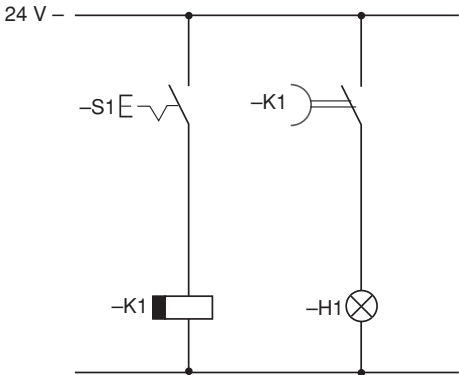

Figur 7.36 Relékobling

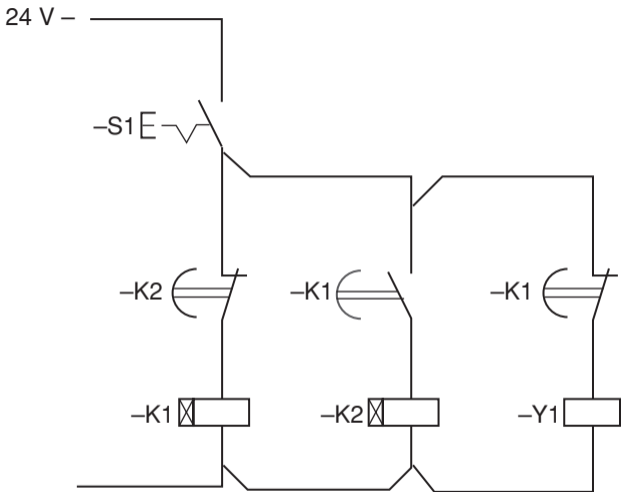

Figur 7.37 Relékobling

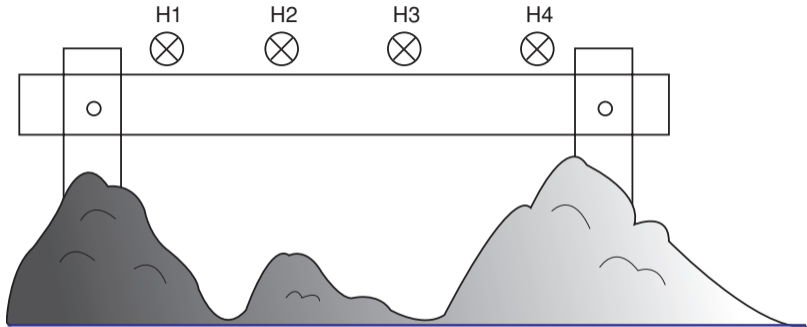

Figur 7.38 Lysbjelke

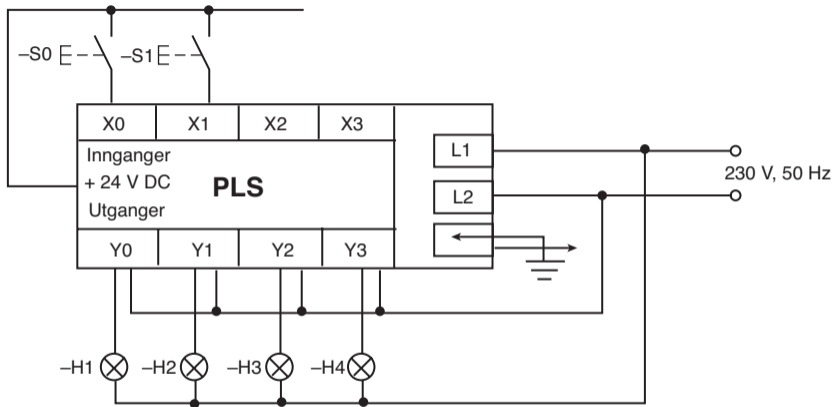

Figur 7.39 Koblinger til PLS-en

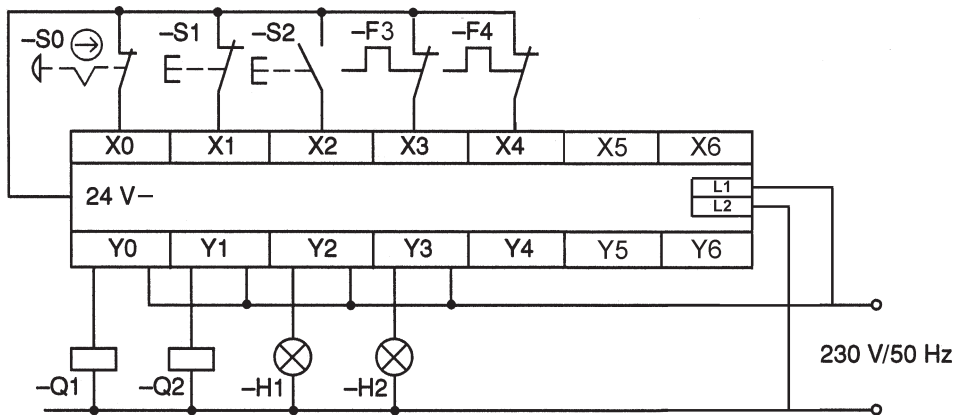

Figur 7.40 PLS-tilkoblinger

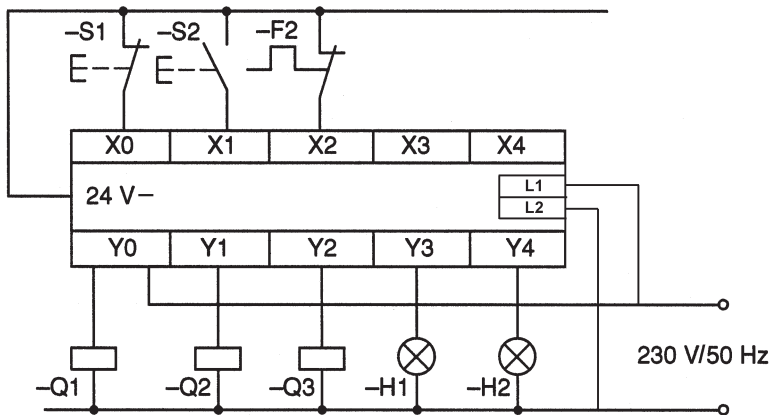

Figur 7.41 PLS tilkoblinger

Oppteller, *Up-counter*

Symbol

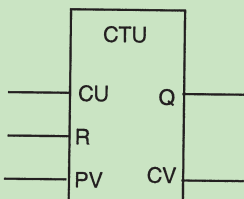

Virkemåte

Når R blir satt til 1, blir CV satt til 0.
Når CU blir satt til 1, øker antall tellepulser på CV med 1, $CV = CV + 1$.
Utgangen Q blir 1 når CV er lik eller større enn PV.

Nedteller, *Down-counter*

Symbol

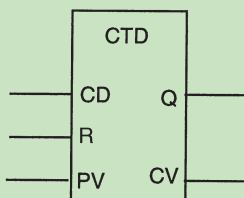

Virkemåte

Når R blir satt til 1, blir CV satt til 0.
Når CD blir satt til 1, reduseres antall tellepulser på CV med 1, $CV = CV - 1$.
Utgangen Q blir 1 når CV er lik eller mindre enn PV.

Opp/ned teller, *Up-down-counter*

Symbol

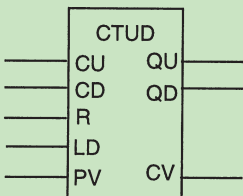

Virkemåte

Når R blir satt til 1, blir CU satt til 0.
Når LD blir satt til 1, blir CV satt til PV. Når CU blir satt til 1, øker tellepulsene på CV med 1, $CV = CV + 1$.
Når CD blir satt til 1, reduseres antall tellepulser på CV med 1, $CV = CV - 1$.
Utgangen QD blir satt til 1 når $CV = 0$.
Utgangen QU blir satt til 1 når $CV = PV$.

Figur 7.42 Tellernes skjemasymbol og funksjon

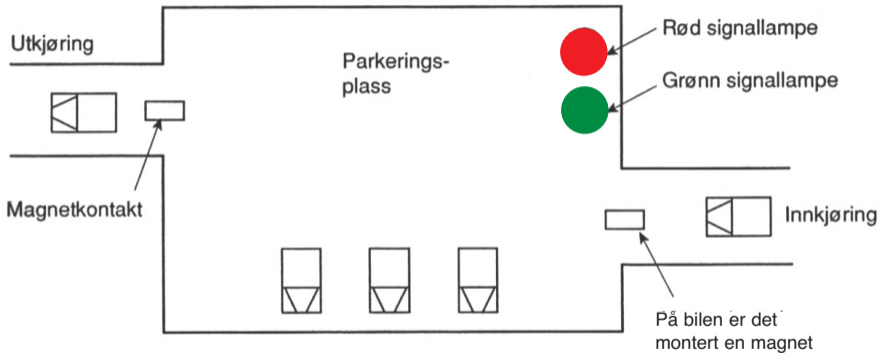

Figur 7.43 Lysregulert parkeringsplass

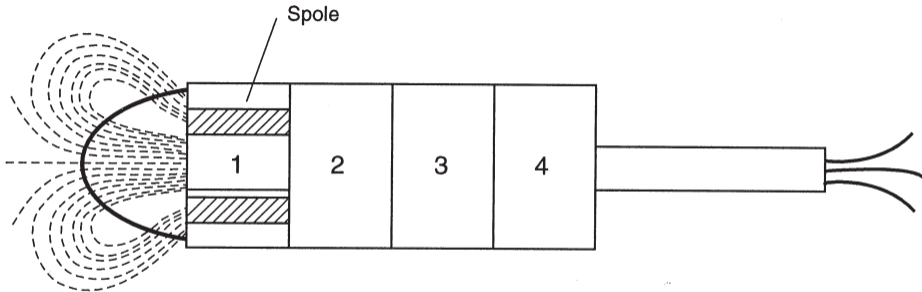

Figur 7.44 Induktiv næreffektbryter skjematisk tegnet

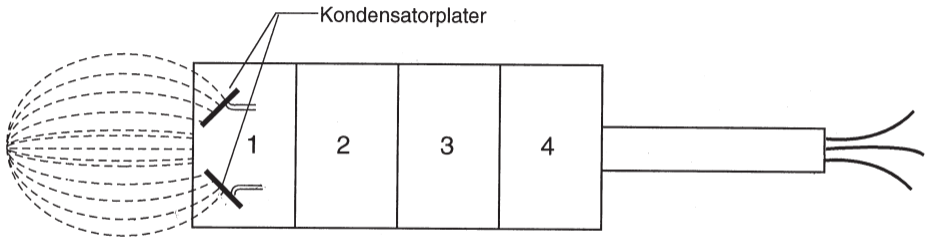

Figur 7.45 Kapasitiv næreffektbryter skjematisk tegnet

Type: Tretrådet PNP

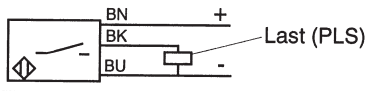

Gir (+) signal i forhold til (-) når den blir aktivisert.
Den gir *ikke* signal når den *ikke* er aktivisert

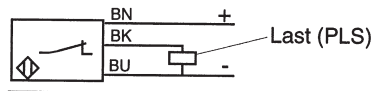

Gir (+) signal når den *ikke* er aktivisert og gir *ikke* signal når den er aktivisert

Type: Tretrådet NPN

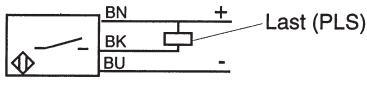

Gir (-) signal i forhold til (+) når den blir aktivisert.
Den gir *ikke* signal når den *ikke* er aktivisert

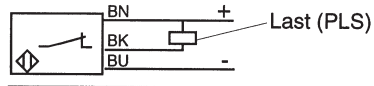

Gir (-) signal når den *ikke* er aktivisert og gir *ikke* signal når den er aktivisert

BN er brun
BK er sort
BU er blå



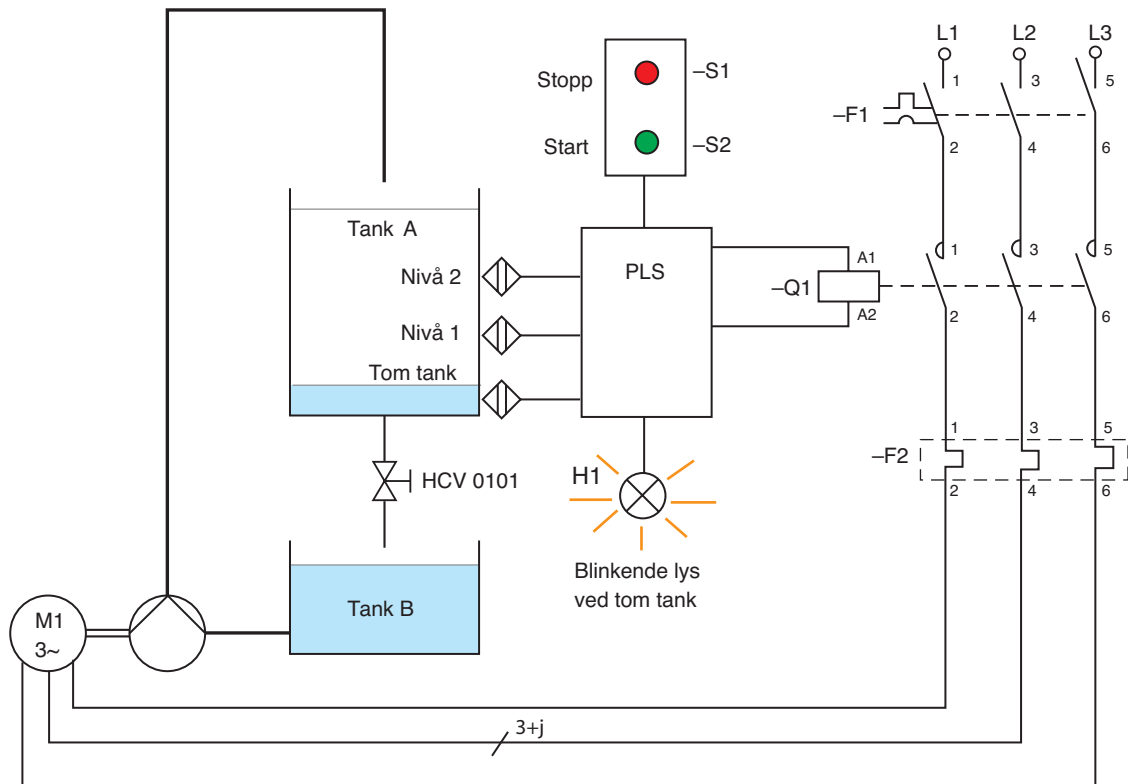



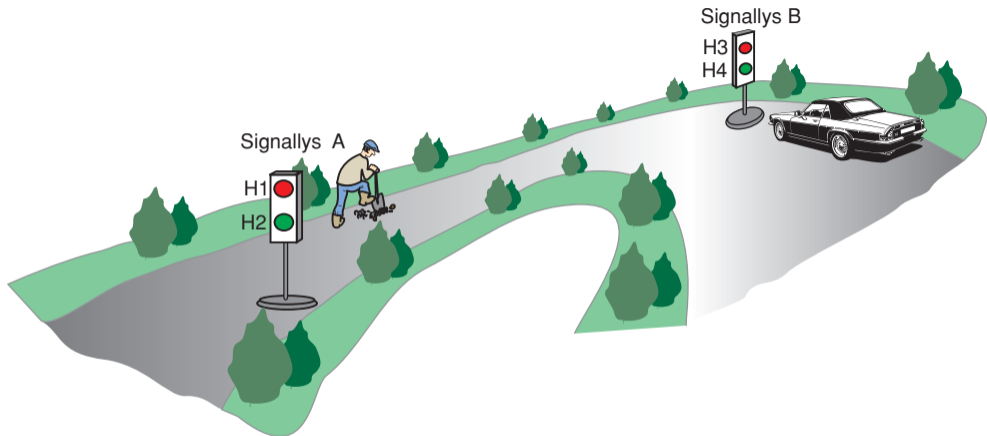









Figur 7.46 Koblingskjemaer for næreffektbrytere



Figur 7.47 Prinsippskisse av pumpeanlegget



Figur 7.48 Lysanlegg for veiarbeid

	Signallys A		Signallys B		Tid i sek.
	H1 rødt	H2 grønt	H3 rødt	H4 grønt	
Trinn 1					5
Trinn 2					10
Trinn 3					5
Trinn 4					10
Trinn 1	Som trinn 1				

Figur 7.49 Funksjonstabell for lysanlegget

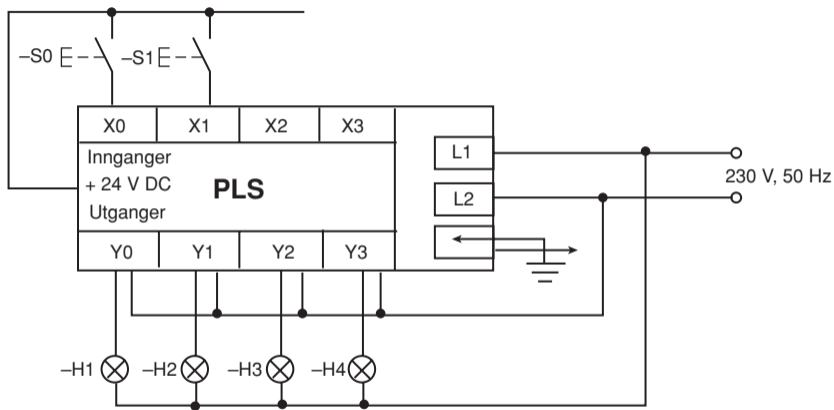

Figur 7.50 Koblingskjema for styring av lysanlegget

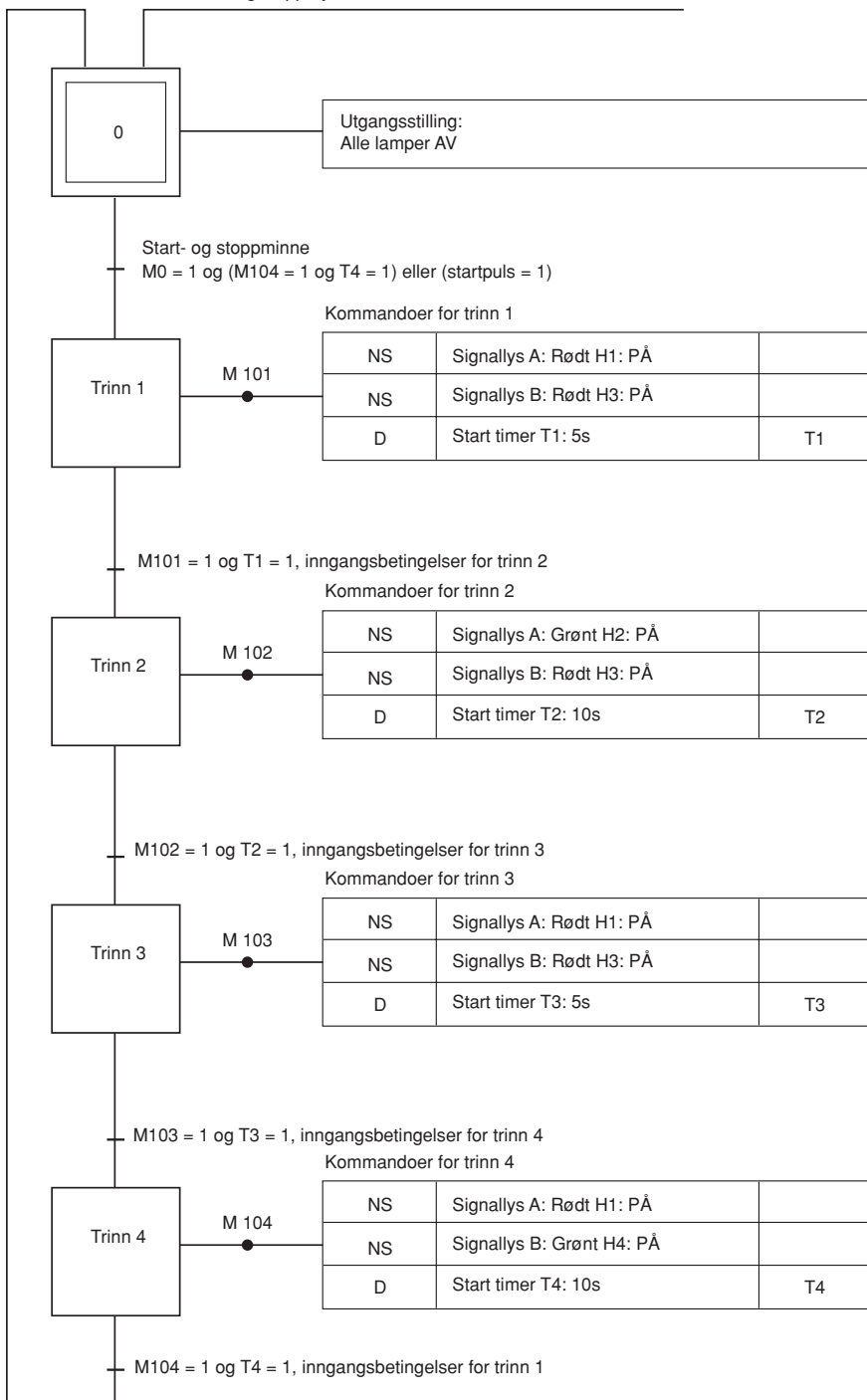

Figur 7.51 Sekvensielt funksjonsdiagram for anlegget



Figur 7.52 Kommandosymbol

NS	Signallys A: Rødt H1: PÅ	
NS	Signallys A: Rødt H3: PÅ	
D	Tidsforsinkelse 5 s. Start timer T1	T1

Figur 7.53 Kommandoer for trinn 1

Startbryter (sluttekontakt) er koblet til inngang: X0
 Stoppbryter (sluttekontakt) er koblet til inngang: X1

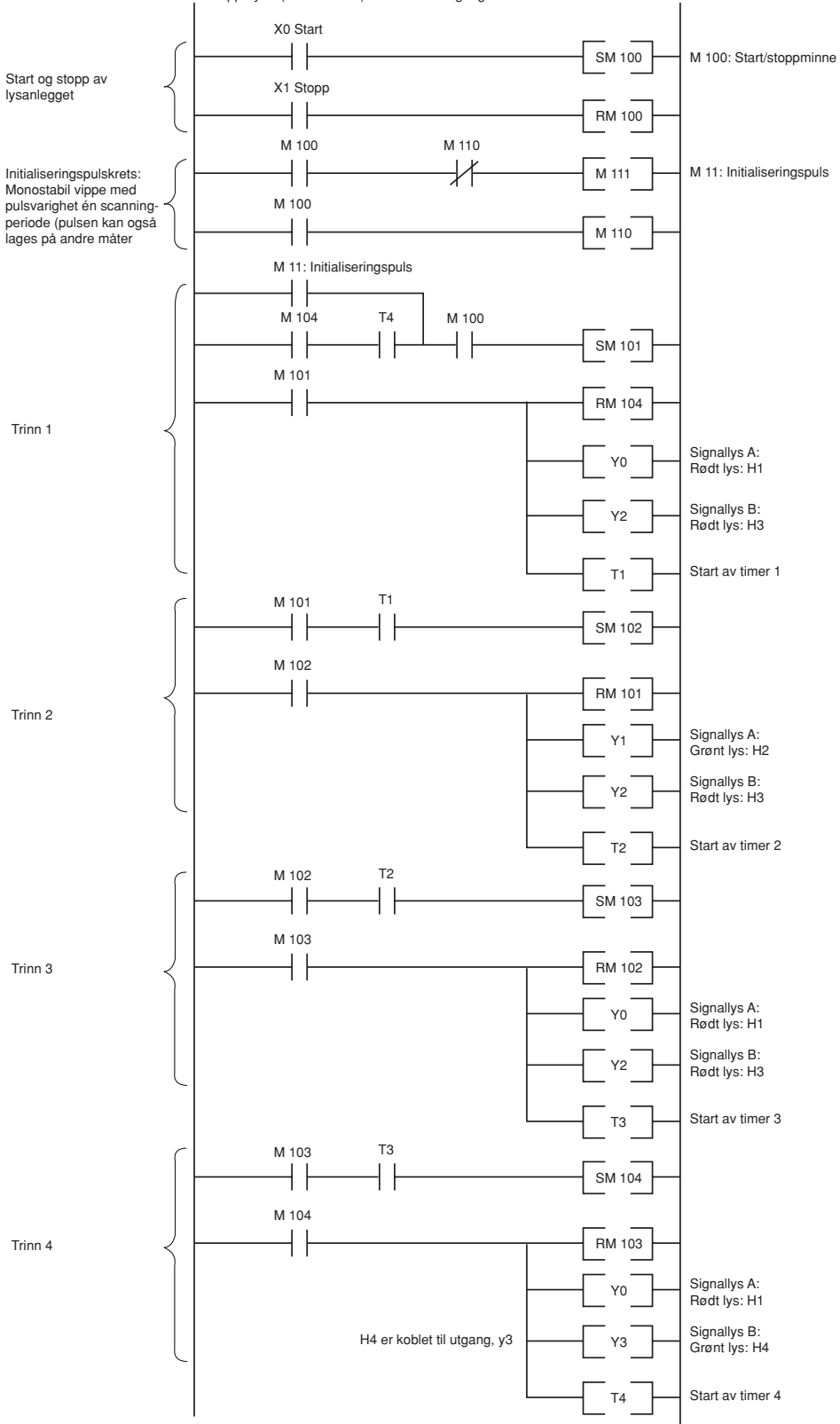

Figur 7.54 Eksempel på et ladderdiagram